

3x5.3 Meter Pergola Aluminium-Stahl

Montageanleitung - DE

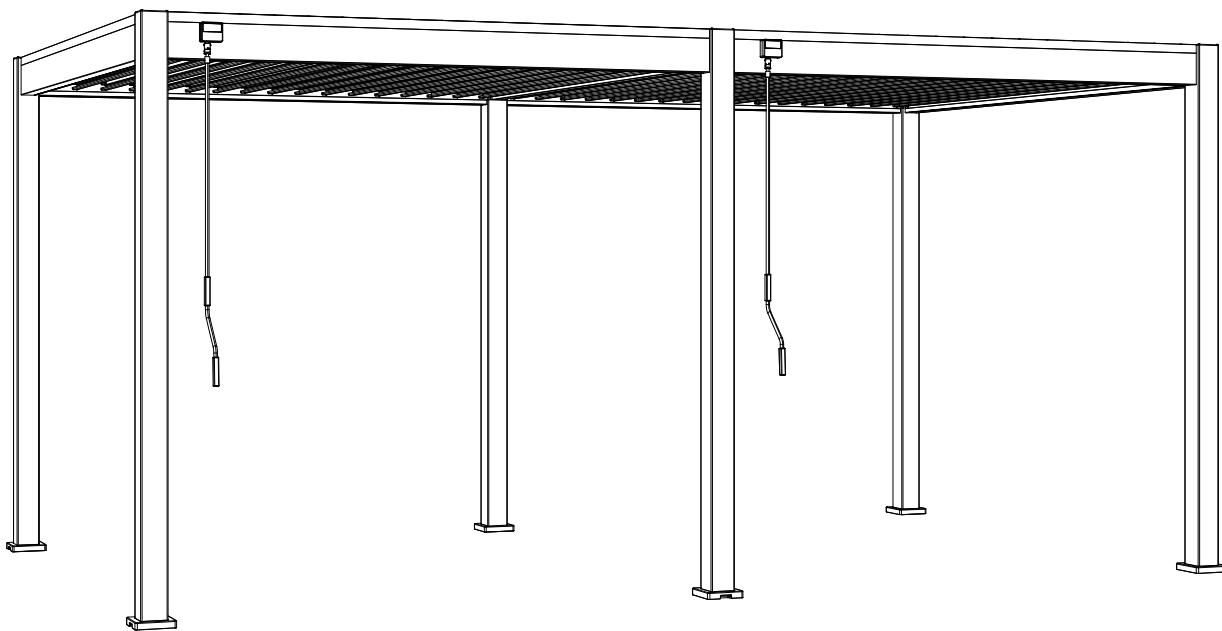

Classic Aluminium-Stahl Pergola 3x5.3 Meter

Bewahren Sie die Anleitung während der gesamten Lebensdauer des Produkts auf. Bitte lesen Sie die Anleitung vor dem Zusammenbau aufmerksam durch. Der Nutzer haftet für Schäden oder Verletzungen, die durch unsachgemäße Verwendung verursacht werden.

Zusätzlich benötigte Werkzeuge und Sicherheitskleidung für die Installation (nicht enthalten)



Sicherheitsbrille
und
Arbeitshandschuhe



2x Leiter



Bohrmaschine
+ 12 mm Bohrer



Akkuschrauber

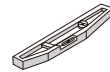

Wasserwaage



Cuttermesser



Sicherheitshelm

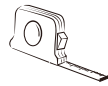

Maßband

2D Fundamentmessung (Dimension in mm)

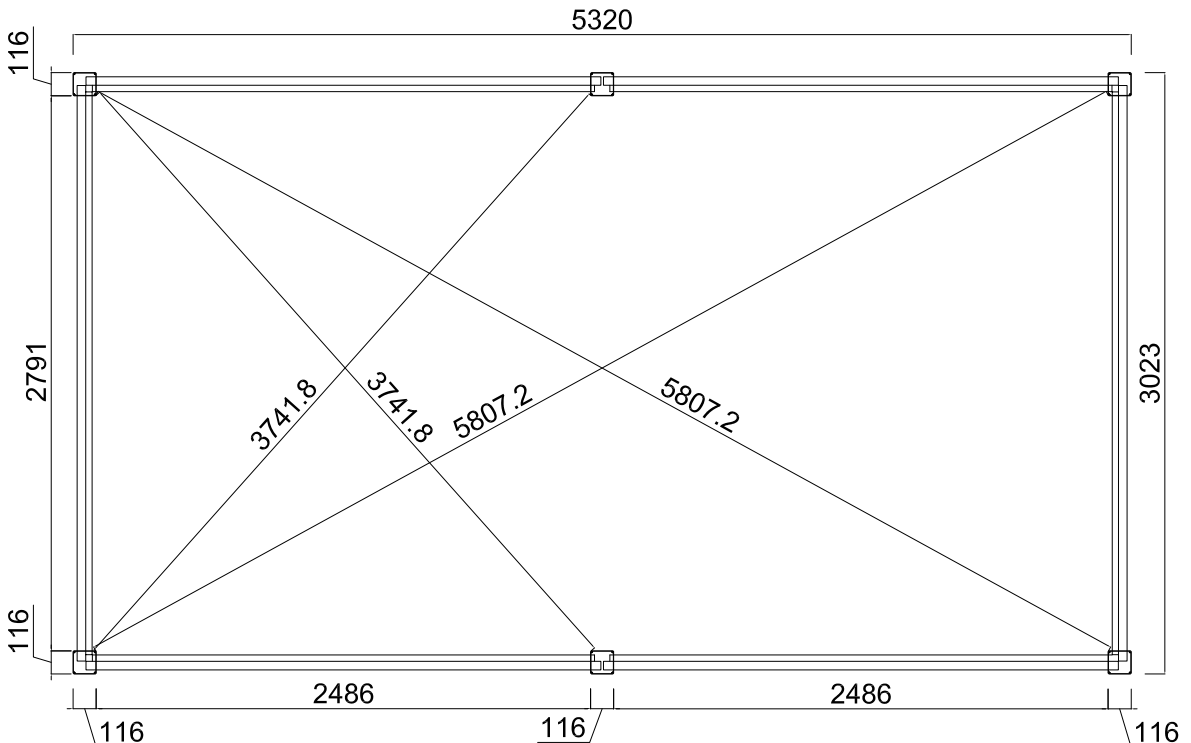

3D-Fundamentmessung (Dimension in mm)

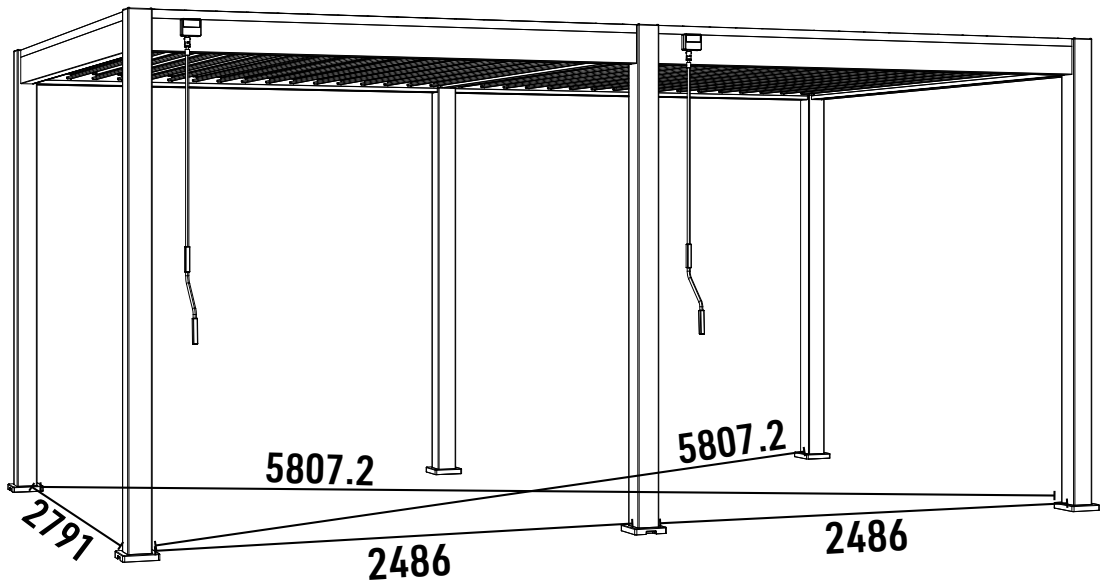

VORSICHTSHINWEISE FÜR DEN GEBRAUCH

Dieses Produkt sollte nicht bei extremen Wetterbedingungen verwendet werden: Stürme, heftiger Wind, Hagel und Schnee. Wir garantieren die Beständigkeit der Pergola für Windgeschwindigkeiten bis zu 100 km/h und eine maximale Schneelast von 50 kg/m².

Bei starkem Schneefall oder Wind, weisen wir ausdrücklich darauf hin die Lamellen zu öffnen. Bitte nicht vergessen, den Schnee vom Dach zu entfernen, um eine starke Überlastung vom Dach zu vermeiden.

Unsere Pergola kann starke Regenfälle standhalten, aber wir können keine absolute Wasserdichtigkeit garantieren.

Bei außergewöhnlichen Wetterereignissen kann die Wasserdichtigkeit beeinträchtigt werden. Lassen Sie keine feuchtigkeitsempfindlichen Produkte unter der Pergola stehen.

Wir raten davon ab, auf das Dach oder das Gestell der Pergola zu klettern. Es besteht die Gefahr von Schäden und Verletzungen.

Tipps und Sicherheitshinweise

Je nach Standort und Fläche kann es sein, dass für den Bau eine Baugenehmigung oder ein Antrag auf Baugenehmigung erforderlich ist. Wir empfehlen Ihnen vor dem Aufbau sich an Ihre Stadtverwaltung zu wenden, um die entsprechenden Informationen zu erhalten.

Produktmontage:

- Es werden 2-3 Personen benötigt
- Entfernen Sie vor der Installation die Schutzfolie von allen Teilen
- Lassen Sie Kinder nicht in der Nähe des Montagebereichs spielen
- Achten Sie auf die Klemmgefahr
- Ziehen Sie die Schrauben nicht vollständig an, bevor Sie die entsprechenden Teile zusammen gebaut haben
- Alle Aufbauschnitte müssen genau befolgt werden
- Diagonalen und Auslotungen kontrollieren
- Befestigen Sie die Pergola erst nach dem Zusammenbau

Es dürfen keine Veränderungen am Produkt vorgenommen werden. Vom Benutzer abgeänderte Produkte, fallen nicht mehr unter die Garantie des Herstellers.

Der Standort sollte mit Bedacht gewählt sein. Es wird empfohlen, die Pergola nicht bei Regen, in der Hauptwindrichtung oder unter einem Baum aufzustellen.

Die Pergola muss auf einem ausreichend stabilen und ebenen Fundament errichtet werden. Es wird empfohlen sie auf einer Betonplatte oder auf 25 x 25 cm großen Betonklötzen an jedem Pfosten zu errichten.

Wenn Sie ihre Pergola in der Nähe des Hauses oder eines Gebäudes aufstellen möchten, achten Sie dar auf, dass Regenrinnen vorhanden sind, damit Regenwasser abfließen kann. Die Pergola kann es nicht aushalten wenn Wasser von Ihrem Haus in die Pergola fließt.

Falls diese Hinweise nicht oder nur teilweise befolgt werden, erlischt die Garantie des Verkäufers.

Wartung

Eine regelmäßige Pflege des Produkts ist nötig um eine Langlebigkeit des Produkts zu gewährleisten.

Empfehlungen:

- Waschen Sie die Pergola 1–2-mal im Jahr mit Süßwasser und einem Schwamm oder Tuch. Verwenden Sie keine aggressiven Reinigungs- oder Scheuermittel.
- Überprüfen Sie regelmäßig (min 1x im Jahr) ob die Schrauben fest angezogen sind.
- Ölen Sie die Eisenwaren regelmäßig (mindestens 1x pro Jahr)
- Achten Sie darauf, dass nichts den Wasserabfluss in den Regenrinnen behindert (Blätter, Äste)
- Entfernen Sie Wasser, das sich an den Füßen der Pergola herum sammelt (heben Sie die Abdeckungen an)

Garantie

Die Garantie umfasst nicht:

- Normale Gebrauchsspuren des Produkts
- Verlust oder Bruch von Teilen beim Auspacken oder bei der Montage
- Mangel an vernünftiger Sorgfalt, Vernachlässigung, Vandalismus, Einwirkung fremder Gegenstände, Gewaltanwendung, Kontakt mit Schleifmittel, Ästhetik, Ausbau, Wiederaufbau oder Verlegung des Standorts.
- Höhere Gewalt: Hagel, starke Winde, Stürme, Schnee, Überschwemmungen, Blitzschlag...
- Veränderung des Produkts durch den Benutzer.

Die Garantie umfasst nur den Ersatz des Ersatzteils oder des gelieferten Produktes, unter Ausschluss jeglicher Kosten und Entschädigungen jeglicher Art.

Die Garantie muss bei der Verkaufsstelle (Geschäft oder Internetseite) beantragt werden, bei der Sie Ihr Produkt gekauft haben.



Teileliste pro Karton













Bevor Sie mit dem Aufbau beginnen, bitten wir Sie alle aufgeführten Bauteile auf Vollständigkeit zu prüfen. Zudem bitten wir Sie nachzuschauen, dass keine Schäden an den Teilen vorhanden sind. Fehlende oder beschädigte Teile müssen binnen 10 Werktagen beim Hersteller reklamiert werden nach Anlieferung der Ware.

















Sie können hierzu gerne unseren Kundenservice kontaktieren.



Entsorgen Sie die Verpackung nicht, ohne sicherzustellen, dass das Produkt richtig funktioniert.



KARTON 1/5 (Pfosten und lose Teile)

Referenz	Teile	Menge
A0		4
A0-1		2



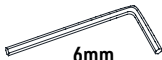

Referenz	Teile	Menge
IO		6
JO		6
KO		2
LO		32
LO-1		34
EO-1		2
MO		66
NO		2
OO		2
PO		2
QO		24
RO		24
SO		68

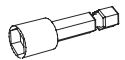
Referenz	Teile	Menge	
S0-1		68	
T0	 10x80	24	
U0	 lock nut	68	
U0-2		66	
W0	 6x12	 4mm	132
W0-1	 5x19	 5mm	6
X0	 6x40	 4mm	66
X0-1	 6x35	 4mm	66
X0-3	 6x16	 4mm	4
V0		66	
Y0	 6x45	 4mm	6

Referenz	Teile	Menge
ZO-1	 4mm	1
ZO-2	 4mm	1
ZO-3	 6mm	1

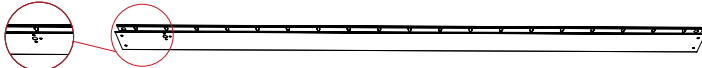
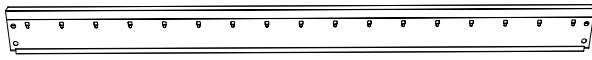
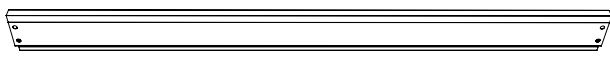
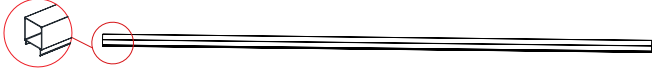

Referenz	Teile	Menge
ZO-4	 6mm	1
ZO-5	 10mm	1
ZO-7		1

KARTON 2/5 (Balken)

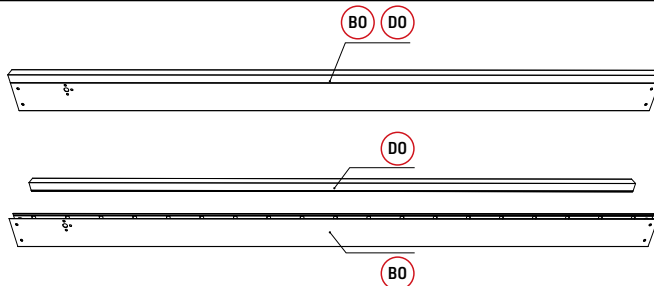

Referenz	Teile	Menge
BO		2
BO-1		2
CO		2
DO		2
EO		1
FO		4
HO		2



KARTON 3/5 (Lamellen)

Referenz	Teile	Menge
GO		10
GO-1		1

KARTON 4/5 (Lamellen)

Referenz	Teile	Menge
GO		10
GO-1		1

KARTON 5/5 (Lamellen)

Referenz	Teile	Menge
GO		12

Schritt 1 (Rahmen)

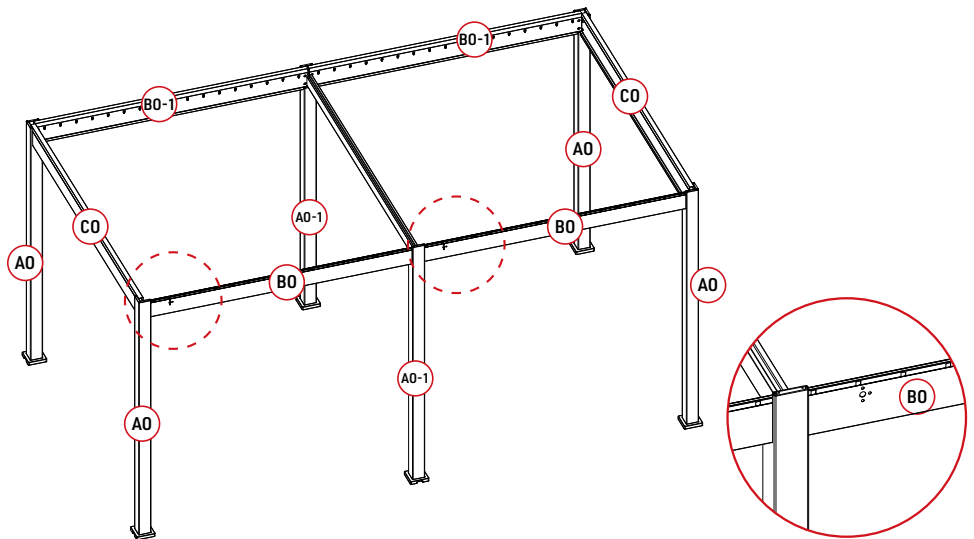

Teile

Referenz	Teile	Menge
AO		4
AO-1		2





Referenz	Teile	Menge
BO		2
BO-1		2
CO		2
EO		1

Referenz	Teile	Menge
IO		6
JO		6
QO		24
EO-1		2



Referenz	Teile	Menge
XO-1		24
XO-3		4
WO-1		6

Schritt 1-1 (Rahmen)

Teile

A0		4
I0		4
J0		4
X0-1	 6x35 4mm	16

Werkzeuge

Z0-1	 4mm	1
Z0-2	 4mm	1

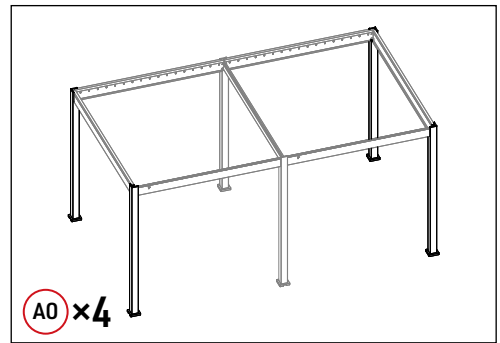

Fertigstell Diagramm

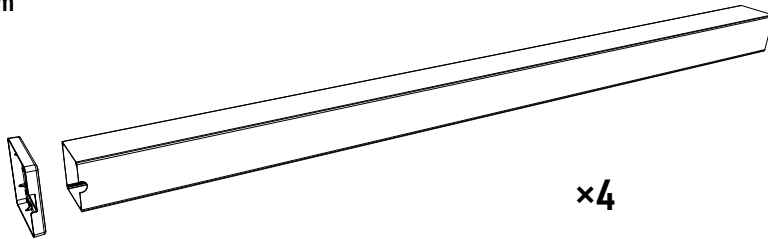

1

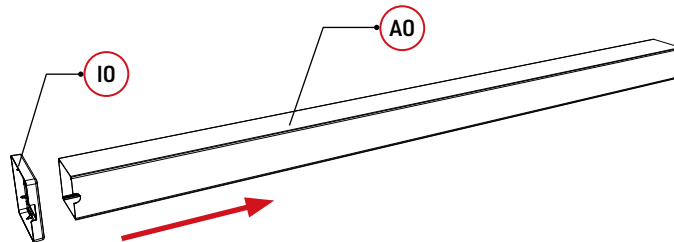

1. Platzieren Sie **I0** in **A0**, stellen Sie sicher, dass die Kerbe um die Säulen **I0** mit dem Abflussauslass ausgerichtet zum Boden der **A0**-Säule ist und platzieren Sie es in der Säule.



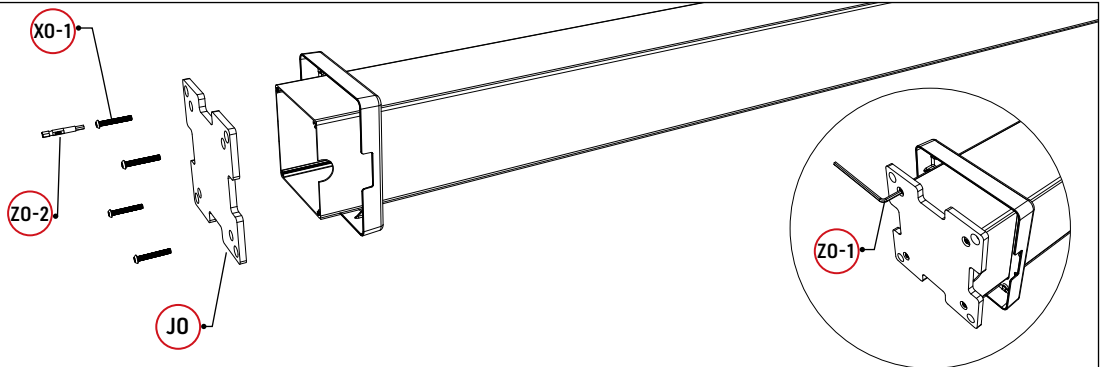

2





2. Befestigen Sie die **J0**-Grundplatte mit **X0-1** an der Unterseite der Säule und ziehen Sie sie mit dem Sechskantschlüssel **Z0-1** manuell fest.

Schritt 1-2 (Rahmen)

Teile

A0-1		2
I0		2
J0		2
X0-1	 6x35 4mm	8

Werkzeuge

Z0-1	 4mm	1
Z0-2	 4mm	1

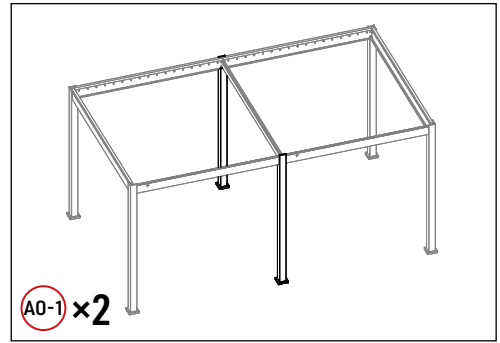

Fertigstell Diagramm

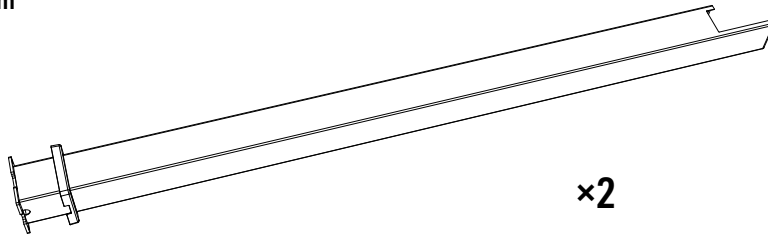

1

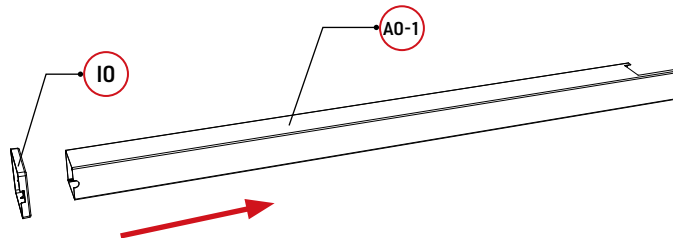

1. Platzieren Sie **I0** in **A0-1**, stellen Sie sicher, dass die Kerbe um die Säulen **I0** mit dem Abflussauslass ausgerichtet zum Boden der **A0**-Säule ist und platzieren Sie es in der Säule.

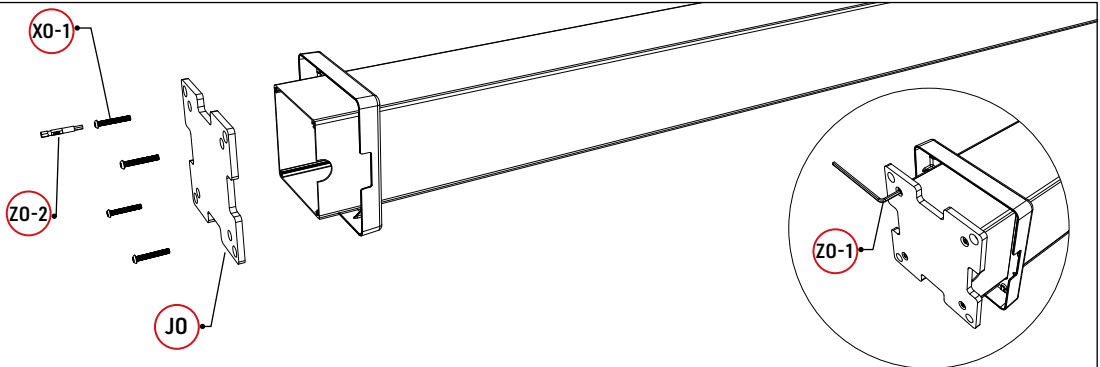

2





2. Befestigen Sie die **J0**-Grundplatte mit **X0-1** an der Unterseite der Säule und ziehen Sie sie mit dem Sechskantschlüssel **Z0-1** manuell fest.

Schritt 1-3 (Rahmen)

Teile

CO		2
QO		8

Werkzeuge

ZO-3	 6mm	1
ZO-4	 6mm	1

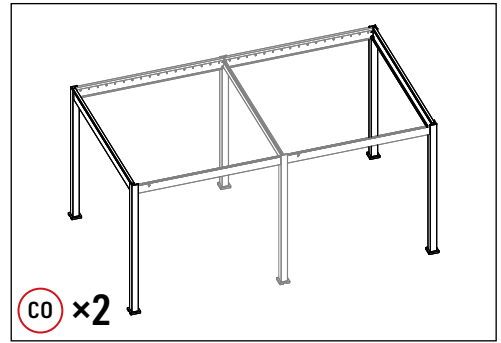

Fertigstell Diagramm

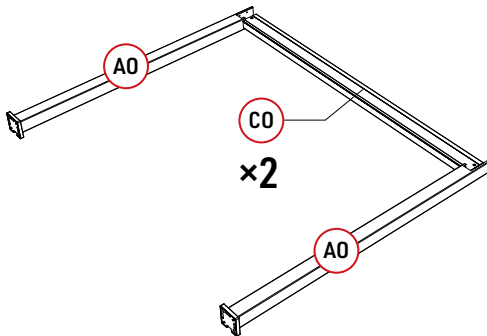

1. Legen Sie die Säule und den Balken flach hin und geben Sie **CO** in die Rille des abgeschlossene Spalte **AO**.

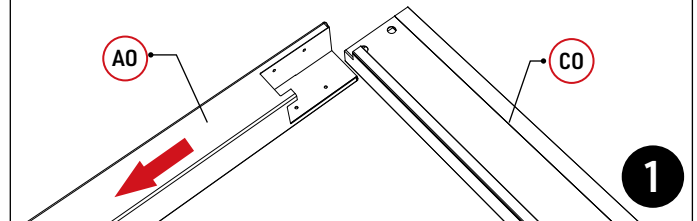

2. Verbinden Sie **CO** mit **AO** mithilfe von **QO**.

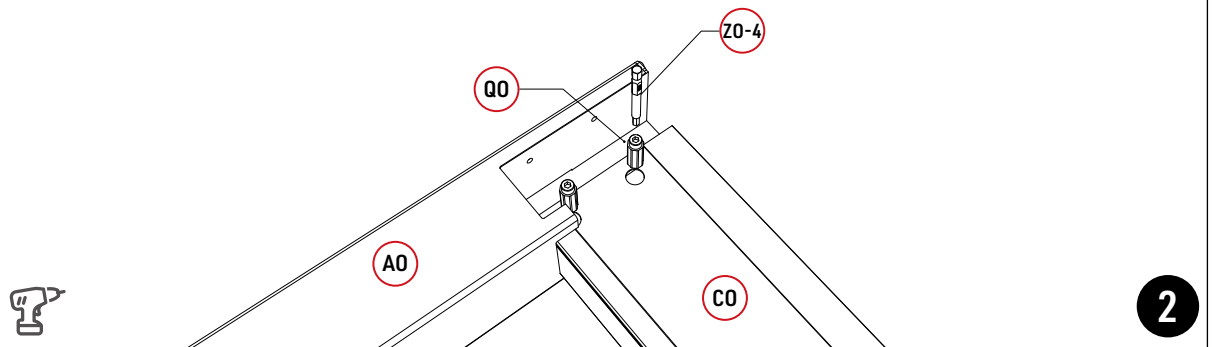

3. Verwenden Sie zum manuellen festziehen den Inbusschlüssel **ZO-3**.

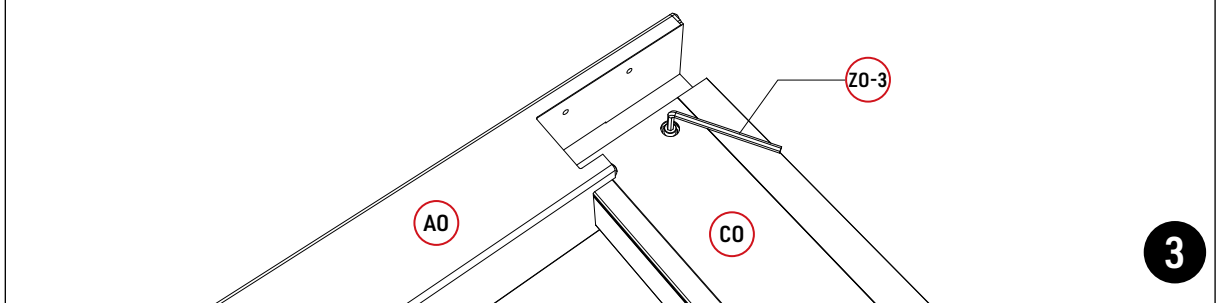

Schritt 1-4 (Rahmen)

Teile

BO		1
BO-1		1

Q0		8
----	---	---

Werkzeuge

Z0-3		1
Z0-4		1

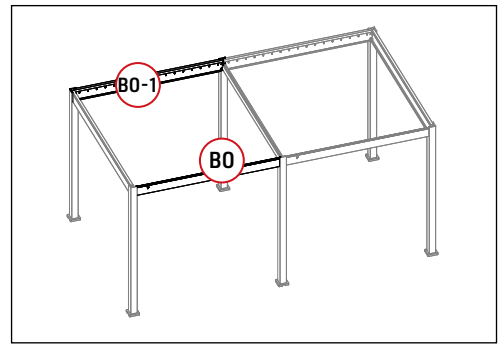

Fertigstell Diagramm

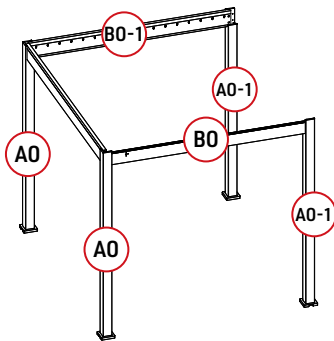

1. Legen Sie die Säule und den Balken flach hin und geben Sie **BO-1** in die Rille des abgeschlossene Spalte **AO**.

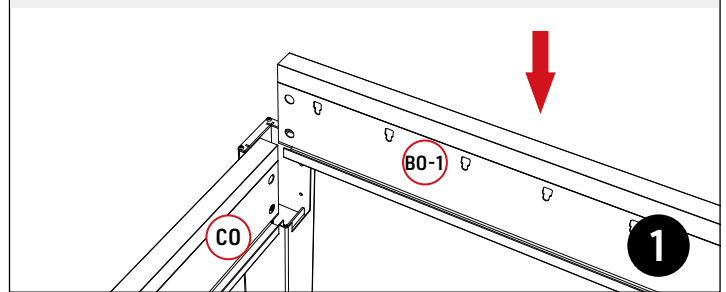

2. Verbinden Sie mithilfe von **Q0**, **BO-1** und **AO** miteinander. Verwenden Sie zum manuellen festziehen den Inbusschlüssel **Z0-3**.

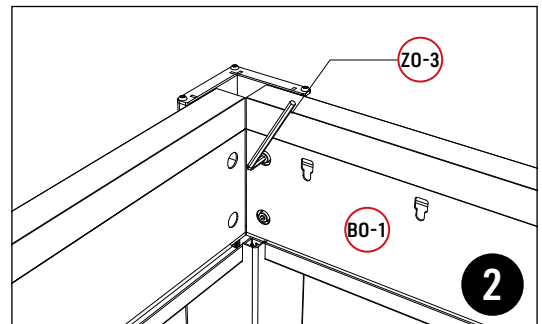
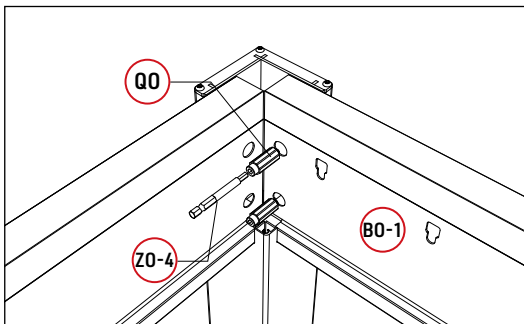

3. Verbinden Sie mithilfe von **Q0**, **BO-1** und **AO-1** miteinander. Verwenden Sie zum manuellen Festziehen den Inbusschlüssel **Z0-3**. **BO** wird auf die gleiche Weise aufgebaut.

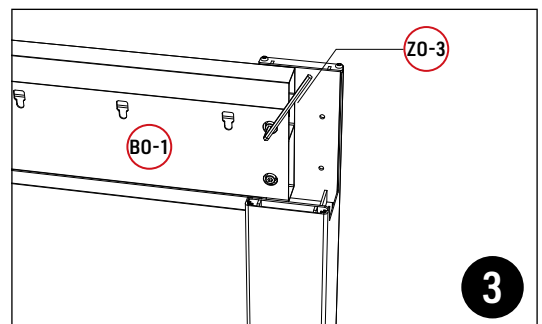
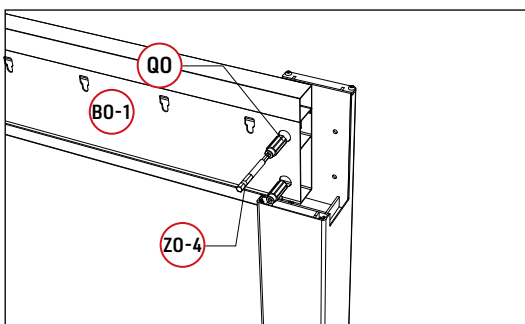

Schritt 1-5 (Rahmen)

Teile

BO		1
BO-1		1

Q0		8
----	---	---

Werkzeuge

Z0-3		1
Z0-4		1

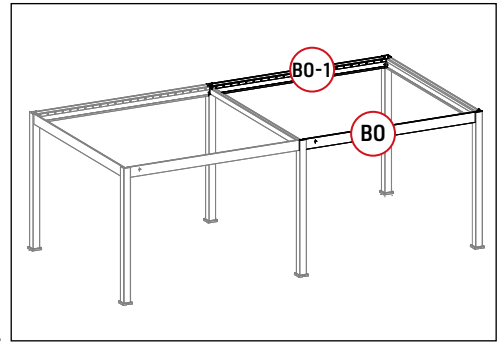

Fertigstell Diagramm

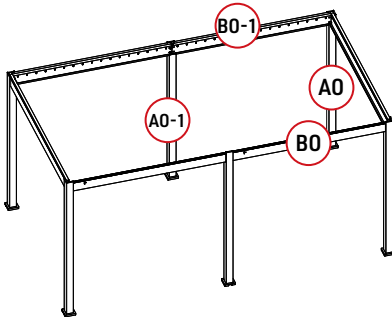

1. Legen Sie die Säule und den Balken flach hin und geben Sie **BO-1** in die Rille des abgeschlossene Spalte **AO**.

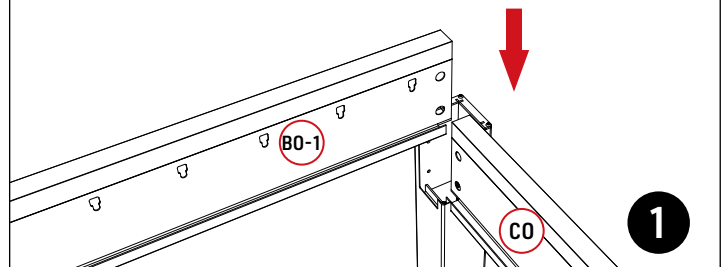

2. Verbinden Sie mithilfe von **Q0**, **BO-1** und **AO** miteinander. Verwenden Sie zum manuellen festziehen den Inbusschlüssel **Z0-3**.

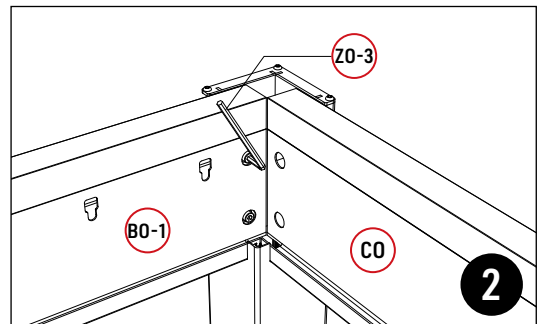
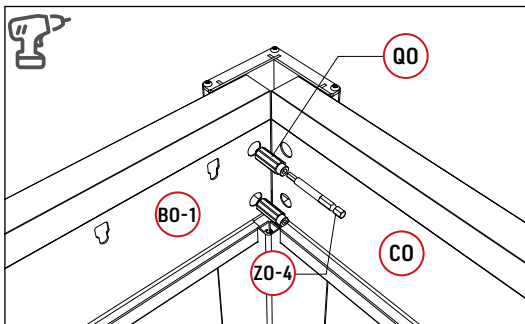

3. Verbinden Sie mithilfe von **Q0**, **BO-1** und **AO-1** miteinander. Verwenden Sie zum manuellen Festziehen den Inbusschlüssel **Z0-3**. **BO** wird auf die gleiche Weise aufgebaut.

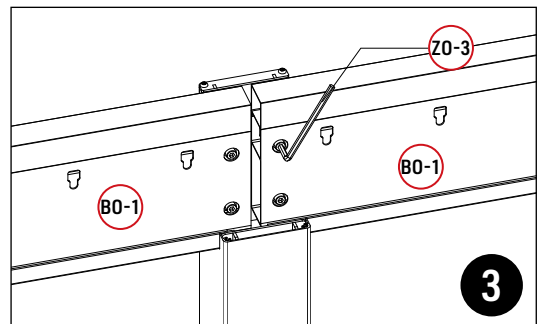
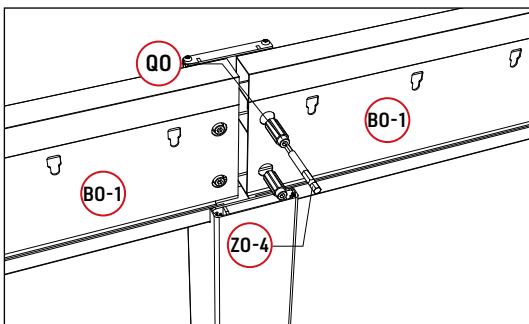

Schritt 1-6 (Rahmen)

Teile

EO		1			
EO-1		2	XO-3		
WO-1		6			

Werkzeuge

ZO-1		1
ZO-2		1
ZO-7		1

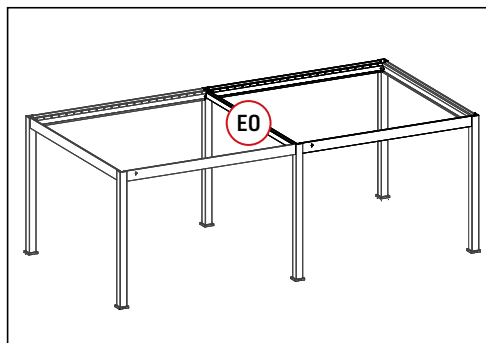

Fertigstell Diagramm

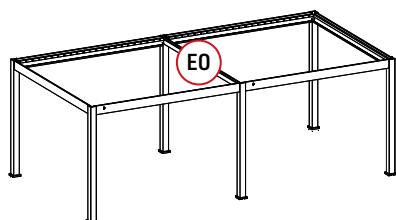

Benutze **EO-1** um beide Seiten von **EO** zu befestigen.

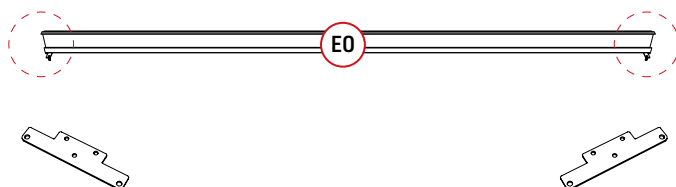

1. Benutzen Sie **WO-1** und **ZO-7** auf beiden Seiten, um **EO1** auf **EO** zu befestigen.

1

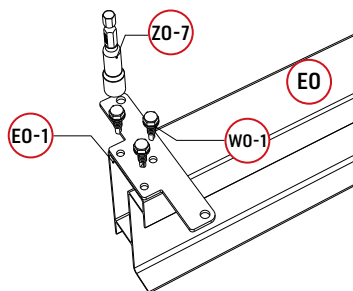

2. Platzieren Sie das installierte **EO** Teil.

2

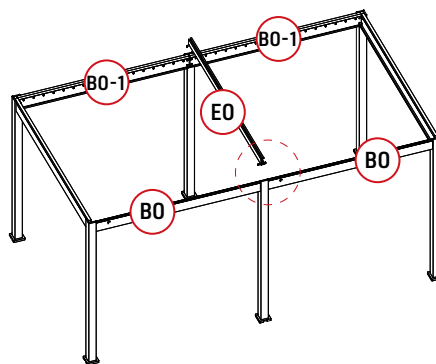

3. Achten Sie auf die Richtung von **EO**. Befestigen Sie den **XO-3** mit dem Werkzeug **ZO-2** an der Mittelsäule.

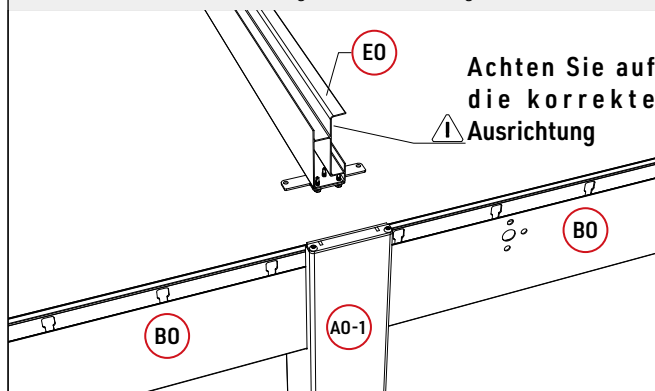

3

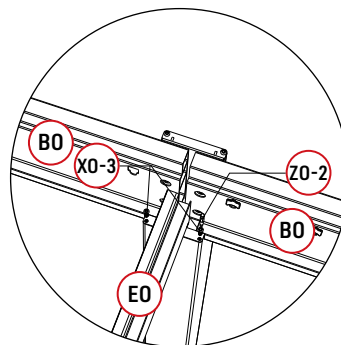

Schritt 2 (Lamellen)

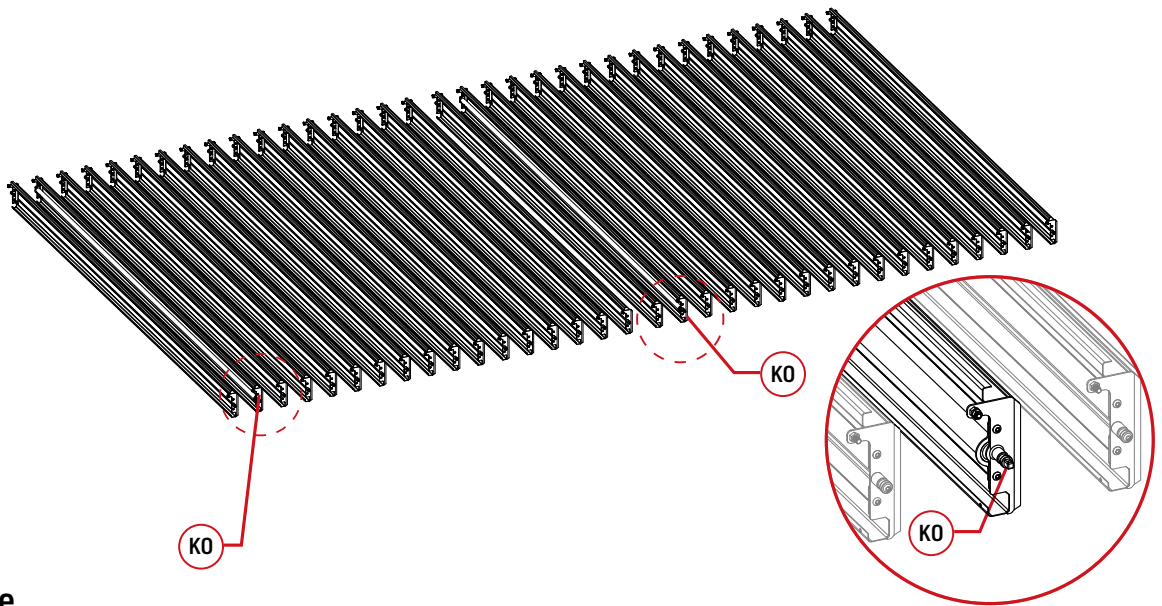

Teile

Referenz	Teile	Menge
GO		32
GO-1		2

Referenz	Teile	Menge
KO		2
LO		32
LO-1		34
MO		66
WO		128
UO		66

Referenz	Teile	Menge
SO-1		68
XO		66

Schritt 2-1 (Lamellen)

Teile

LO		32	UO	lock nut	66
LO-1		34	XO	6-40 4mm	66
MO		66			

Werkzeuge

ZO-1	4mm	1
ZO-2	4mm	1
ZO-5	10mm	1

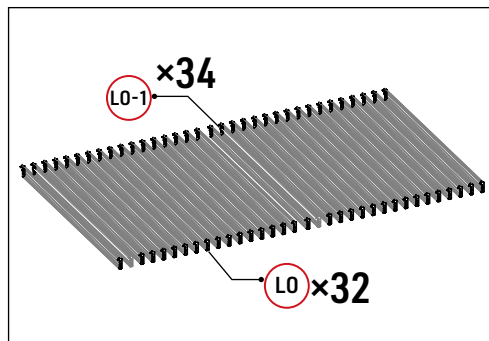

Fertigstell Diagramm

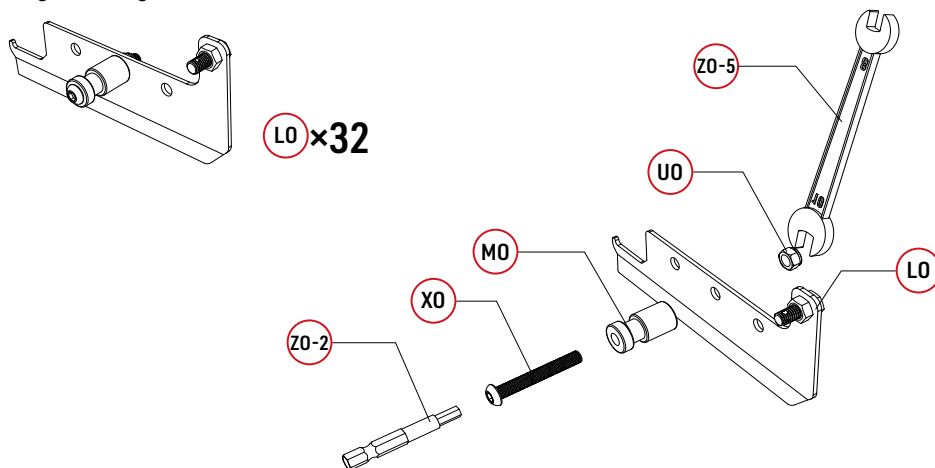

Verwende **ZO-5** um **UO** zu befestigen und die Montage des **LO** abzuschließen.

Fertigstell Diagramm

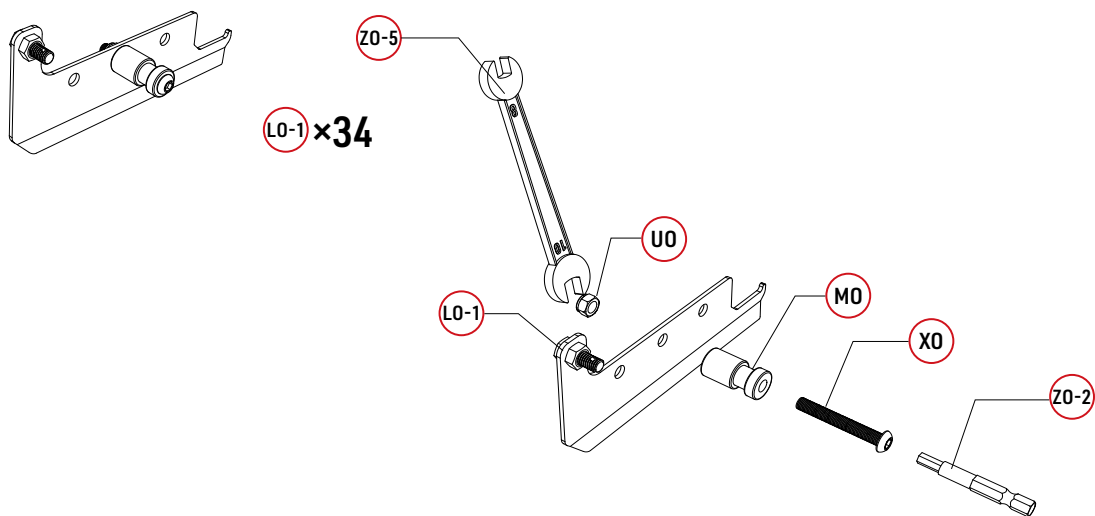

Verwende **ZO-5** um **UO** zu befestigen und die Montage des **LO** abzuschließen.

Schritt 2-2 (Lamellen)

Teile

GO-1		2			
KO		2	WO		
LO-1		2		6x12 4mm	8
			UO		8

Werkzeuge

ZO-1		4mm	1
ZO-2		4mm	1
ZO-5		10mm	1

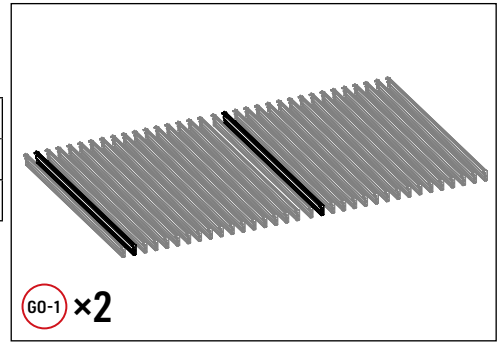

Fertigstell Diagramm

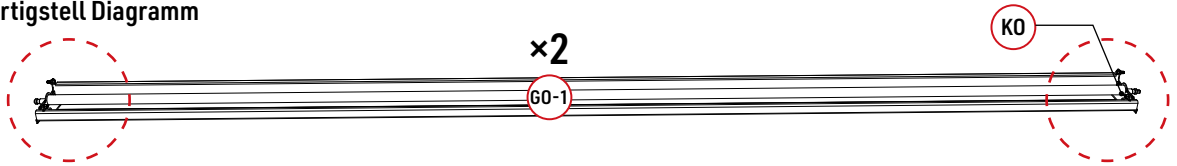

Entfernen Sie die Schrauben von beiden Enden des **GO-1**.

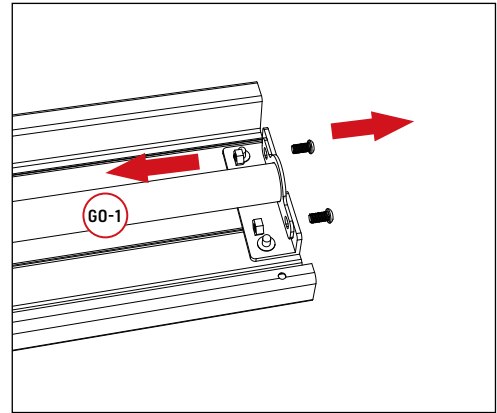
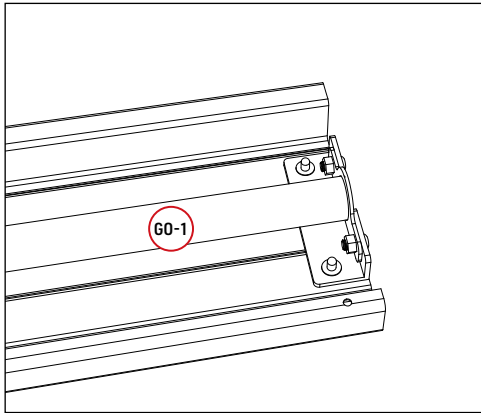



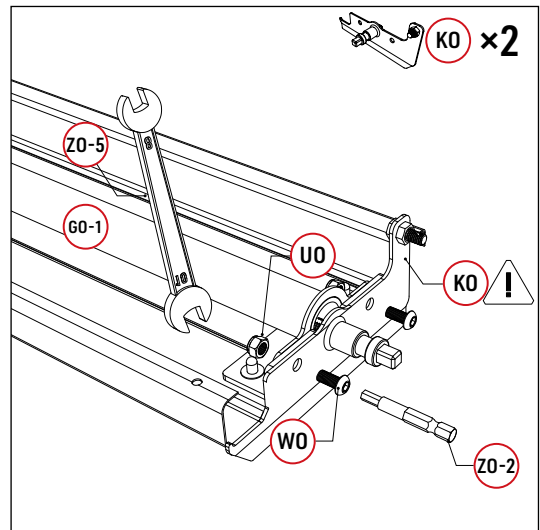
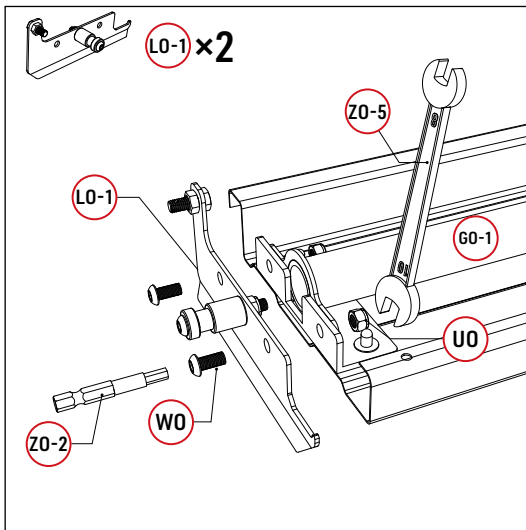



Montieren Sie die beiden Verbindungsstücke auf beiden Enden der Lamellen.



Schritt 2-3 (Lamellen)

Teile

GO		34				
LO		32	WO			128
LO-1		32	UO			128

Werkzeuge

ZO-1		1
ZO-2		1
ZO-5		1

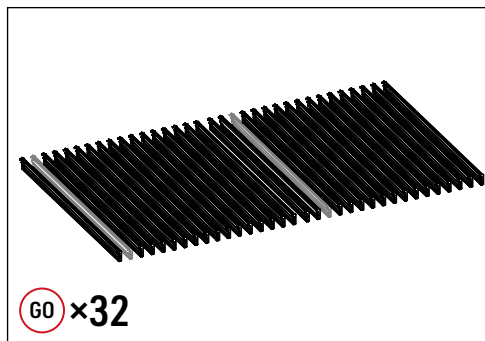

Fertigstell Diagramm

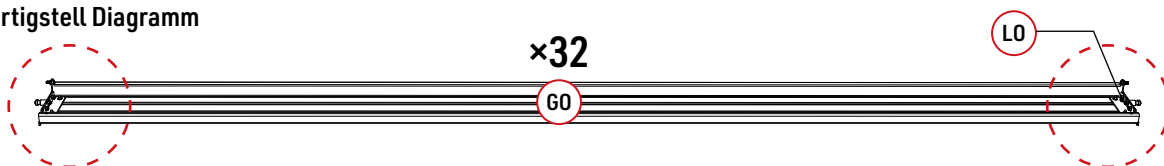

Montieren Sie die beiden Verbindungsstücke auf beiden Enden der Lamellen.

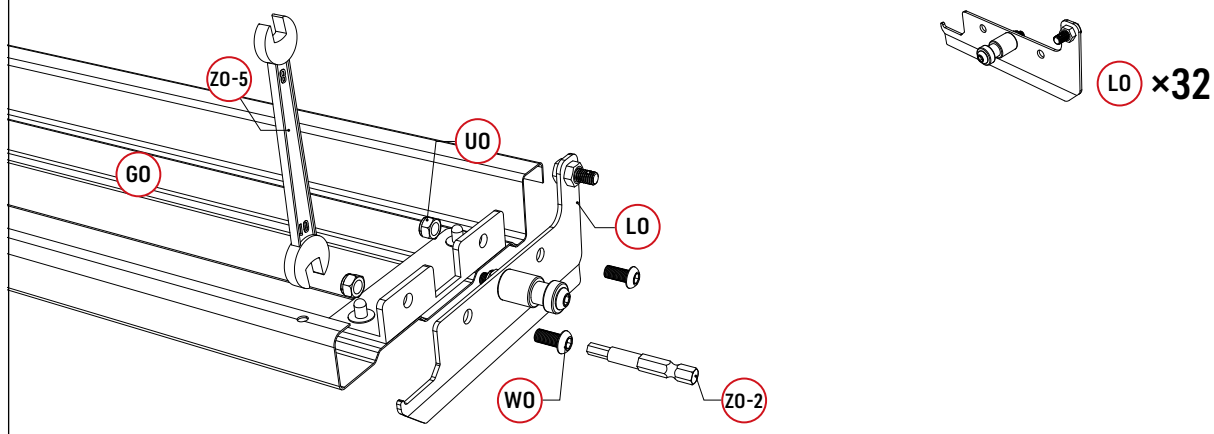

Montieren Sie die beiden Verbindungsstücke auf beiden Enden der Lamellen.

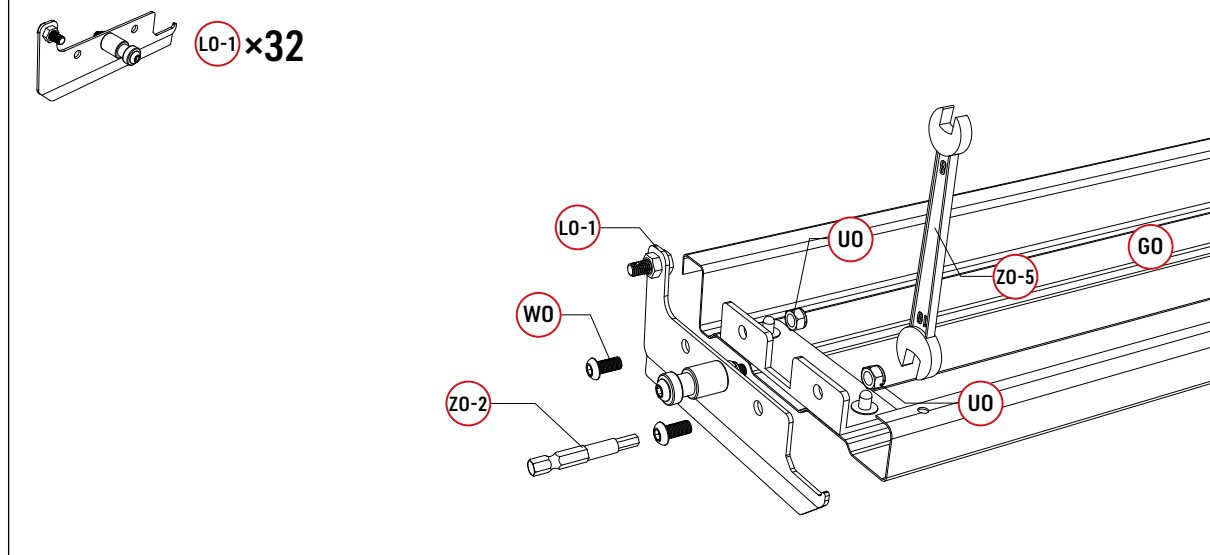

Schritt 2-4 (Lamellen)

Teile

S0-1		68
------	---	----

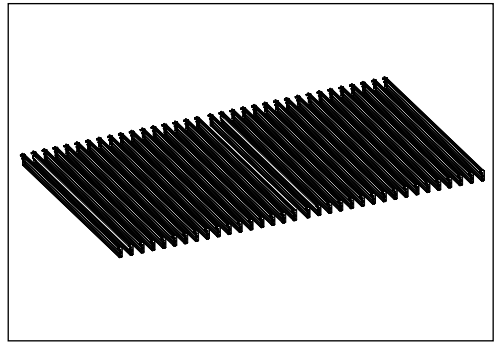

Montieren Sie **S0-1** an beiden Enden der Lamellen.

G0-1 ×2

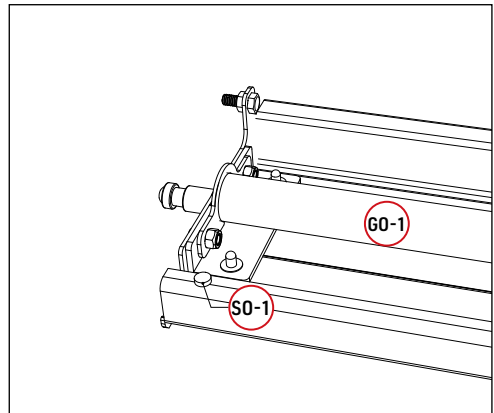
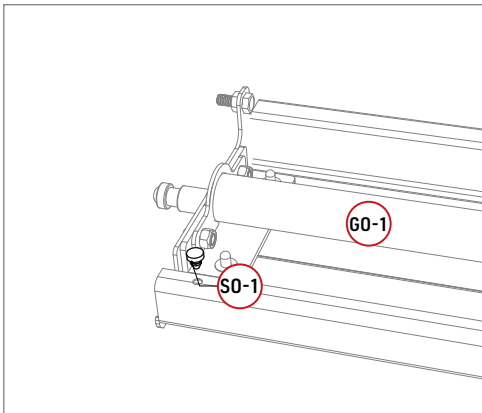

Montieren Sie **S0-1** an beiden Enden der Lamellen.

G0 ×32

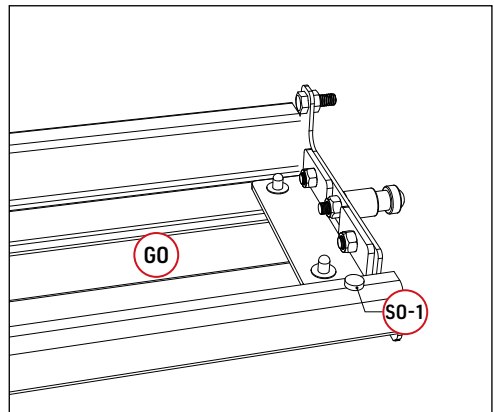
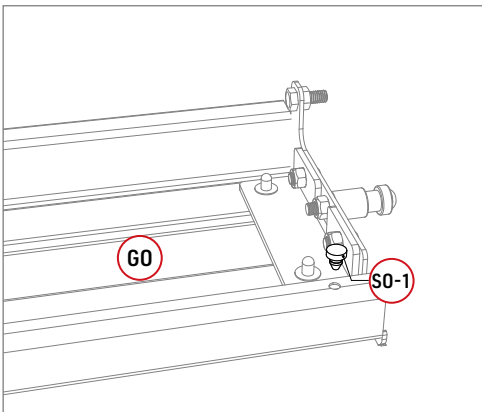

Schritt 3 (Verbinden)

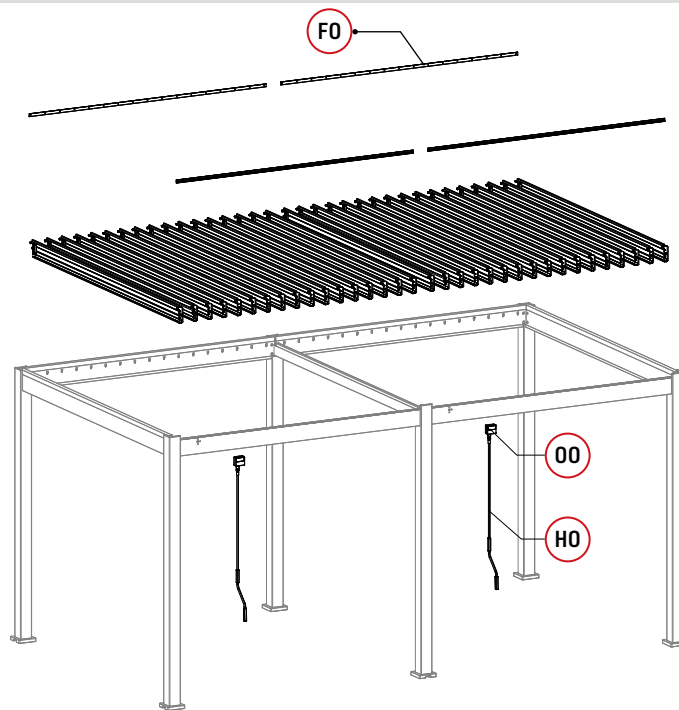

Teile

Referenz	Teile	Menge
FO		4
HO		2

Referenz	Teile	Menge
NO		2
OO		2
PO		2
RO		24
SO		68

Referenz	Teile	Menge
UO	 lock nut	4
UO-2		64
VO		64
YO	 6×45 4mm	6
TO	 10×80	24

Schritt 3-1 (Verbinden)

Teile

SO		68
----	---	----

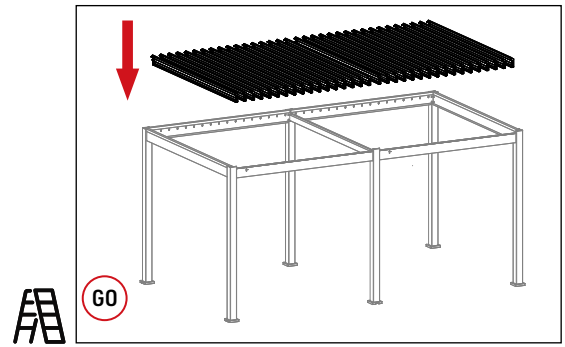

Platziere **GO-1** im Balken.

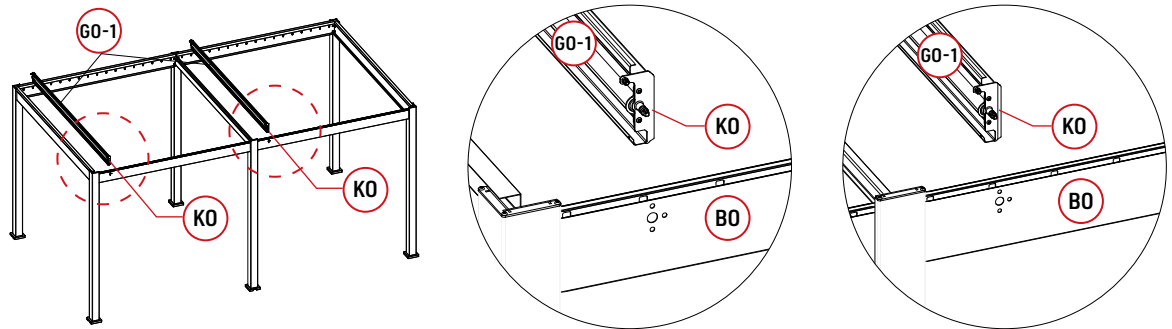

Platzieren Sie **KO** in den Hohlraum des Teils **BO** wie auf dem Bild zu sehen.

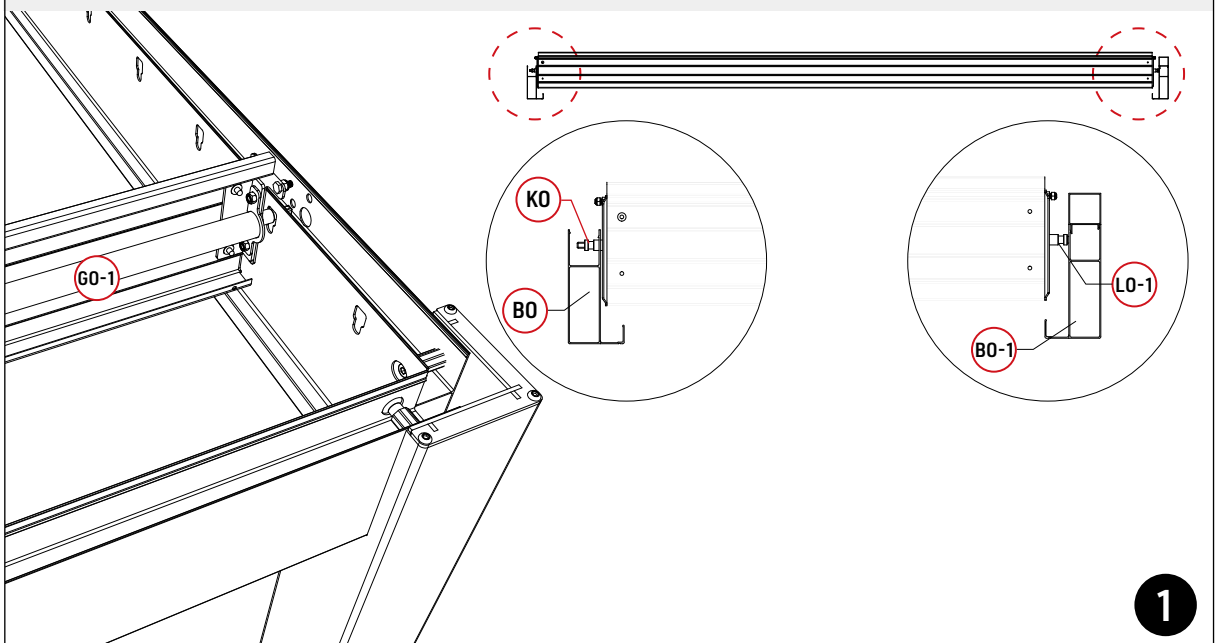

Setzen Sie dann einen weiteren Abschnitt in **BO-1** ein und verriegeln Sie die Rille.

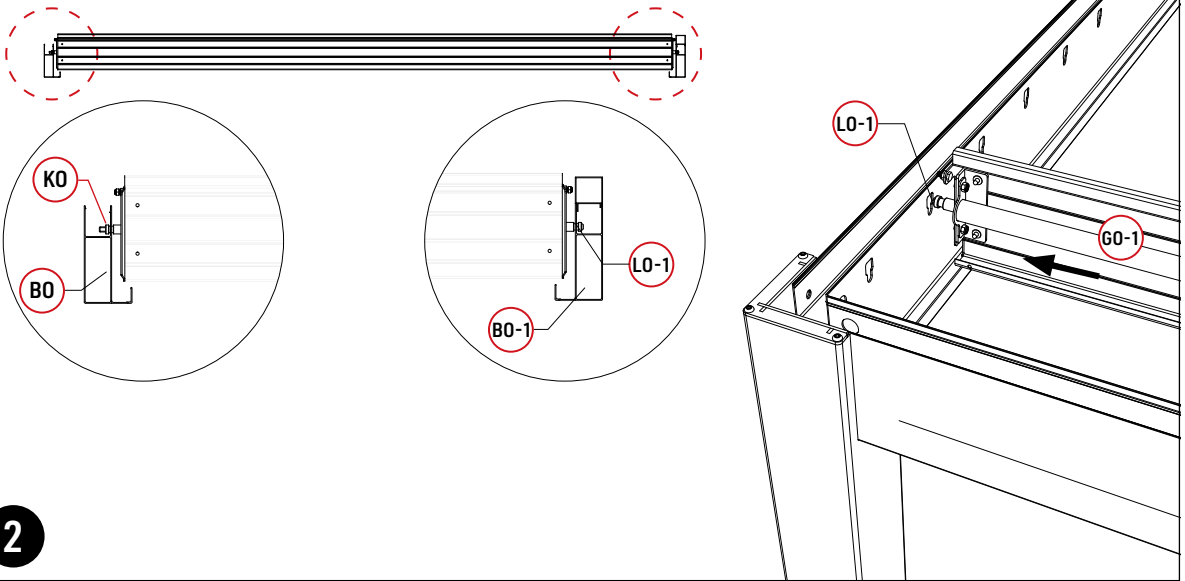

2

Setzen Sie die andere Lamellen ein.

GO ×32

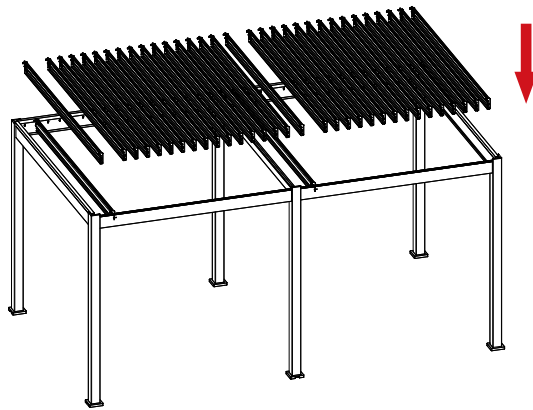

SO dichtet beide Seiten des Balkens ab.

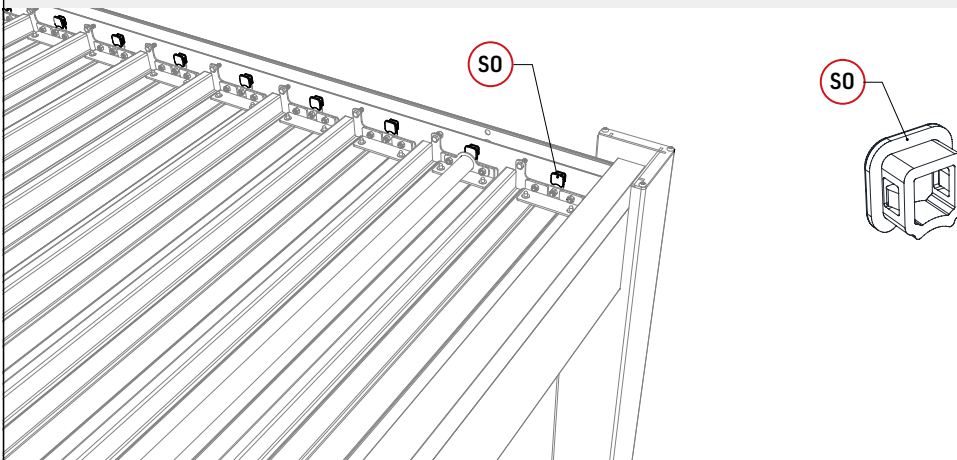

Schritt 3-2 (Verbinden)

Teile

HO		2	YO		6
NO		2			
OO		2			
PO		2			

Werkzeuge

Z0-1		1
Z0-2		1

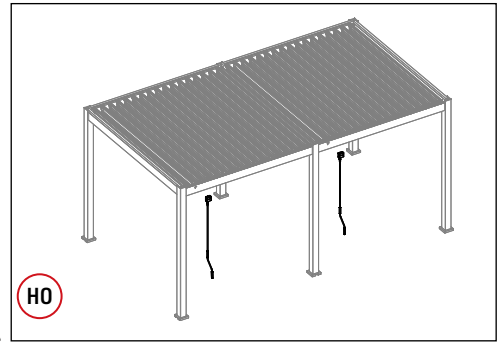

HO

1. Setzen Sie die **PO**-Spindel in das Loch ein.

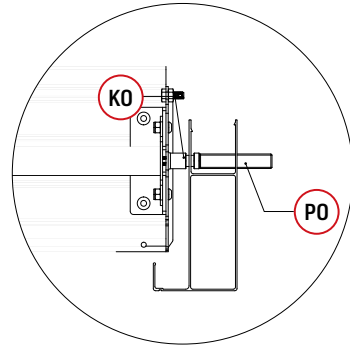
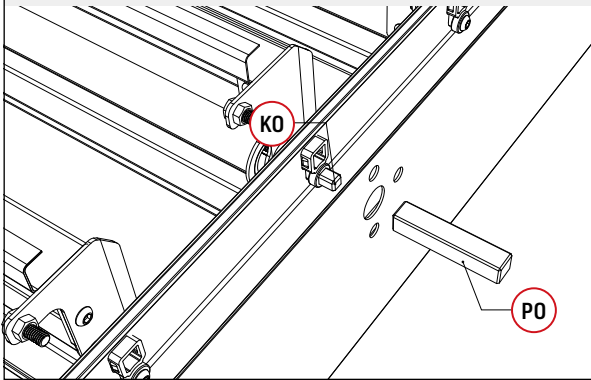

2. Platzieren Sie zuerst **OO**, dann montieren Sie **NO** und befestigen es anschließend mit **YO**.

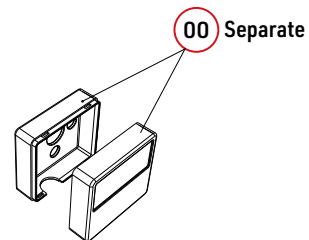
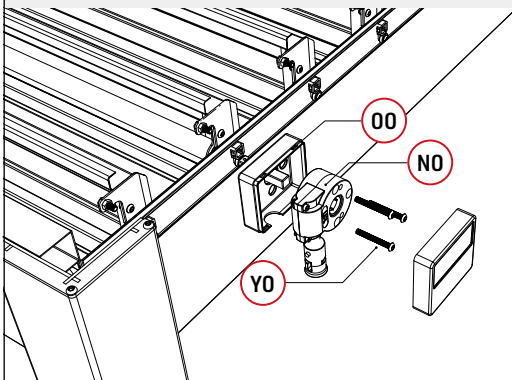



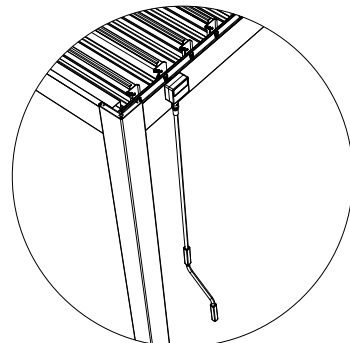
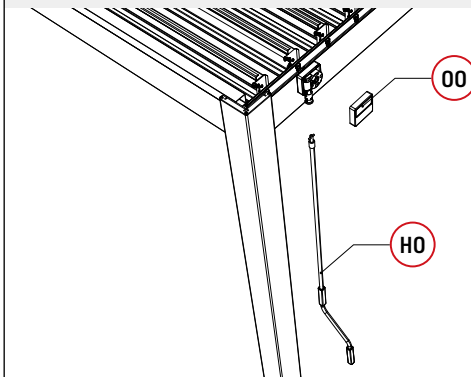

3. Befestigen Sie **NO** und bauen Sie **HO** zusammen.



Schritt 3-3 (Verbinden)

Teile

F0		4
U0	 lock nut	4
V0		64
U0-2		64

Werkzeuge

Z0-1	 4mm	1
Z0-2	 4mm	1
Z0-5	 10mm	1

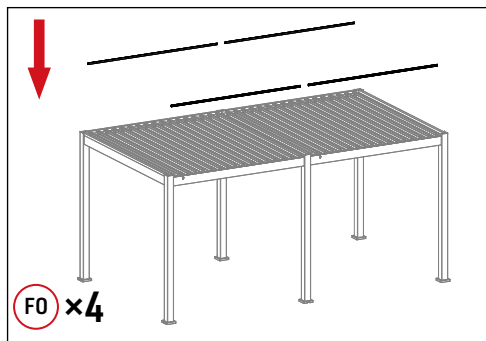

Platzieren Sie das **K0**-Ende wie im Bild gezeigt in den Hohlraum des Teils **B0**.

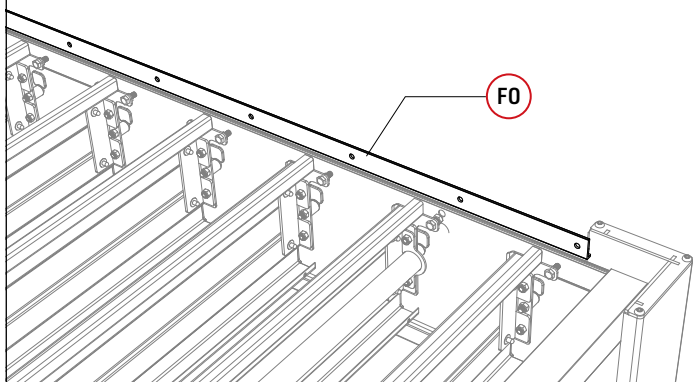

Verwenden Sie **U0** an beiden Enden der Spindel **G0-1**, um beide Enden des Teils **F0** zu befestigen.

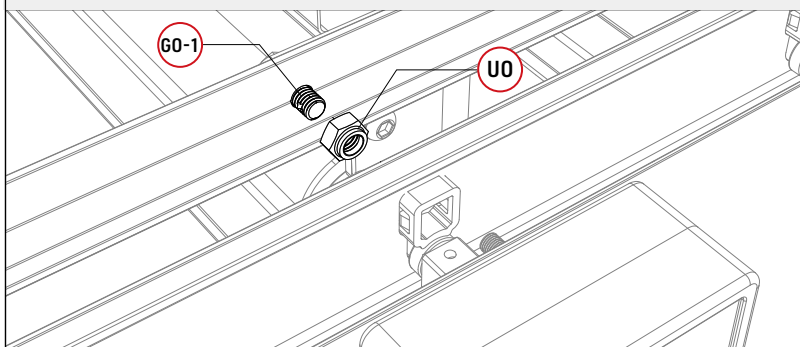

Bitte verwenden Sie die unten gezeigte **V0**-Dichtung. Setzen Sie **U0-2** in das Loch der Endkappe ein.

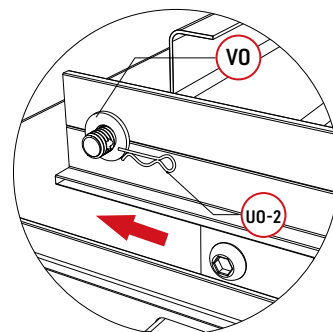
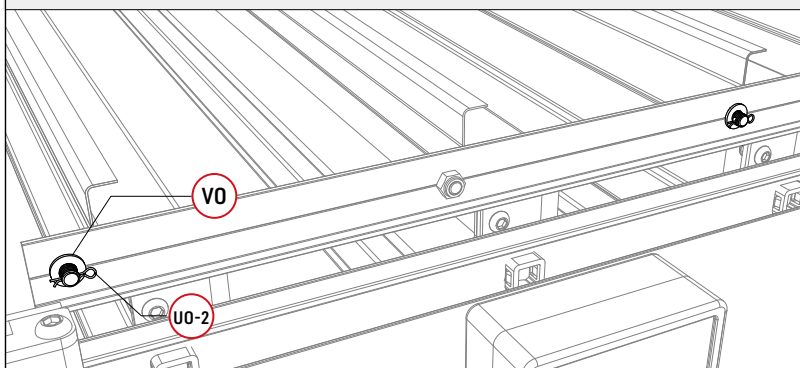

Schritt 3-4 (Verbinden)

Teile

DO		2
RO		24
TO		24

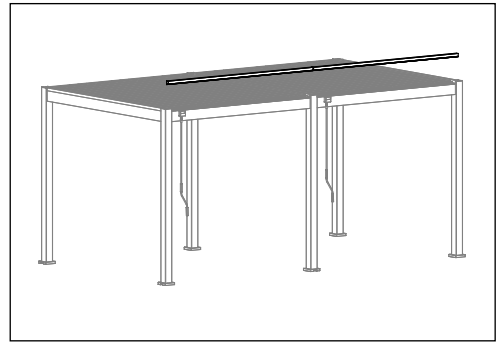

Decken Sie die Löcher im Balken mit **RO** ab.

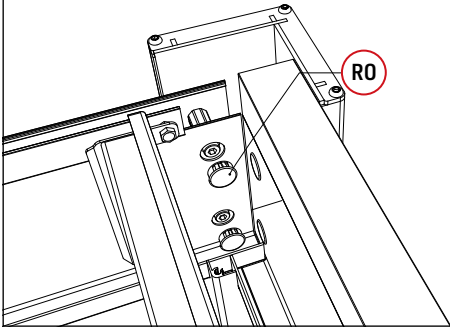

Decken Sie **DO** auf dem Balken ab

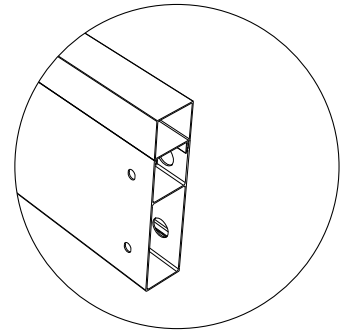
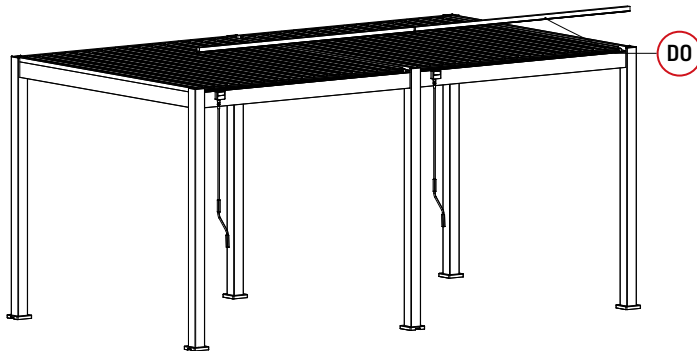

Überprüfen Sie die Größe. Bohren Sie mit einem Ø12-mm-Bohrer Löcher an der Stelle, an der die Stahlplatte befestigt werden soll und befestigen Sie diese dann mit **TO**. Verwenden einen M17-Schlüssel zum Befestigen von **TO**.

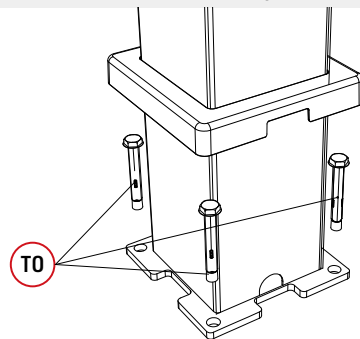
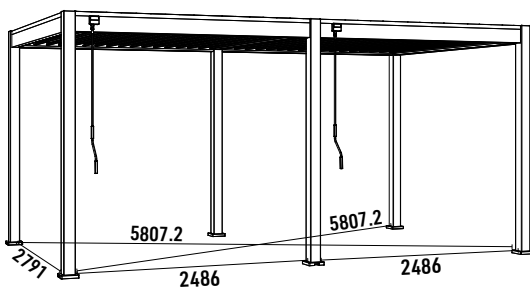

12MM



M17

3x5.3 meter Pergola Aluminium-Steel

Assembly Instructions - EN

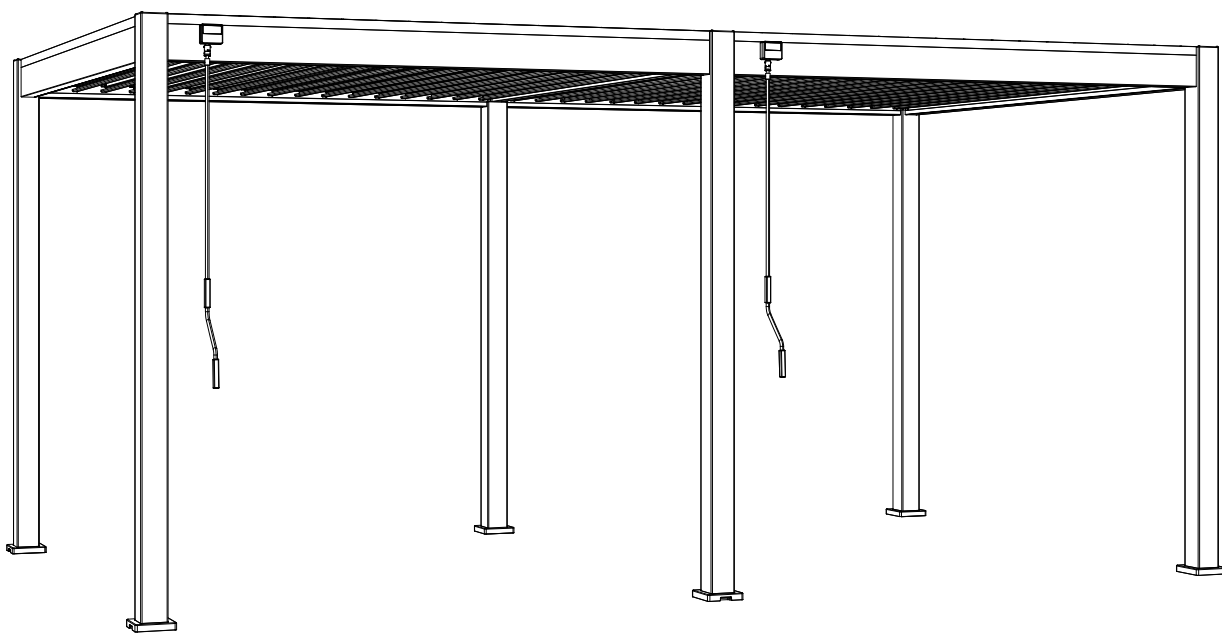

Classic Aluminium-Steel Pergola 3x5.3 meter

These instructions have to be saved during the whole product life cycle. We advise you to read these very carefully before proceeding to the assembly. The user will be reliable for any damages or injuries caused due to incorrect or improper installation.

NECESSARY TOOLS AND SAFETY GEAR (NOT SUPPLIED)



Safety glasses and
Work gloves



2 Ladders



Electric drill + 12mm
concrete drill bit



Electric screwdriver

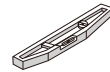

Spirit level



Cutter



Safety Helmet

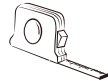

Tape measure

2D FOOTING MEASUREMENT (dimensions in mm)

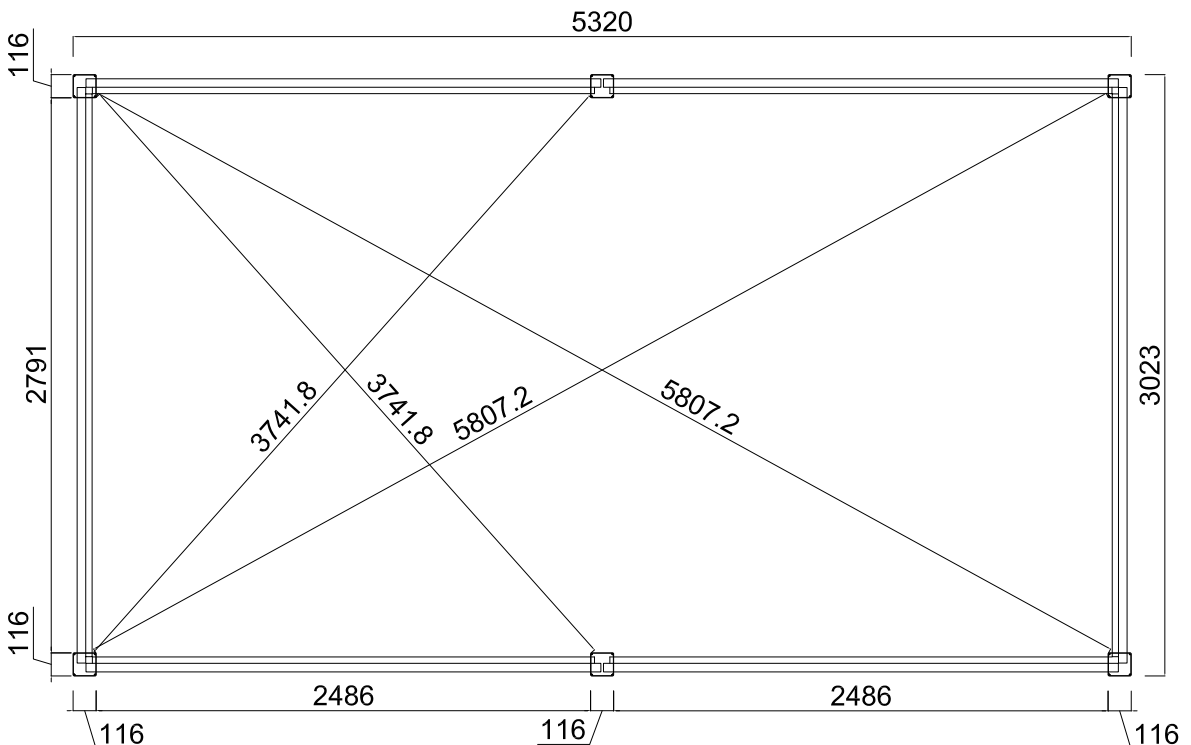

3D FOOTING MEASUREMENT (dimensions in mm)

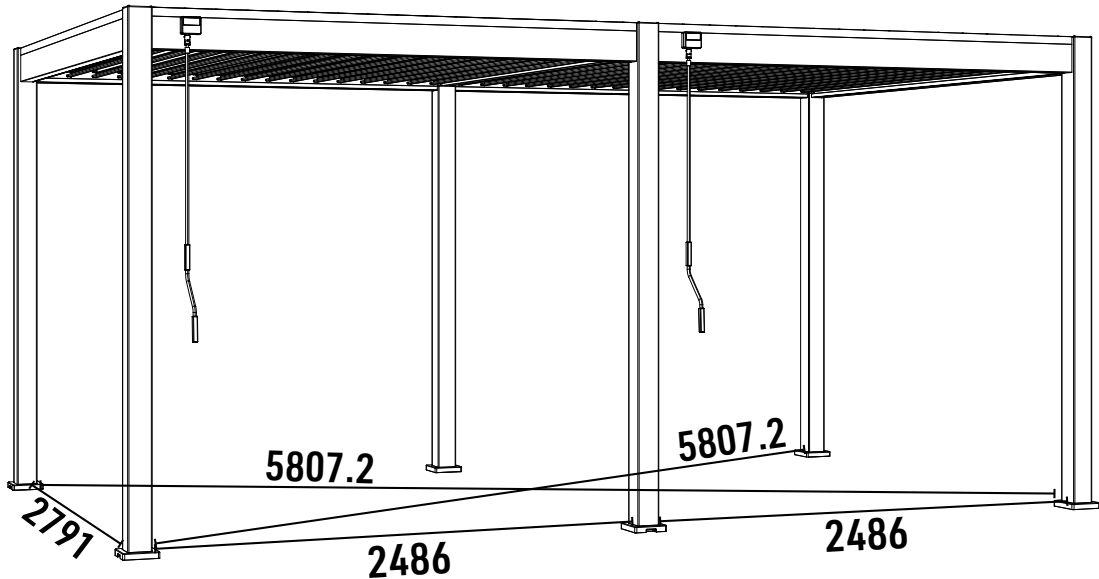

PRECAUTION OF USE

This product should not be used in extreme weather: storms, violent winds, hail, and snow. We guarantee the resistance of the pergola for winds up to 100 km/h and a maximum snow weight of 50kg/m².

As in the case of strong winds or snow, we highly recommend leaving the louvers open. To maintain good working conditions of your louvers, please clear any snow on them.

Our pergola can withstand heavy rain, but we cannot guarantee it will be 100% waterproof due to some extreme weather conditions.

Exceptional climatic events may compromise the perfect sealing of the product.

To avoid any damages and injuries, we do not recommend climbing on the roof or the structure of the pergola.

TIPS AND SAFETY INSTRUCTIONS

Depending on the location and surface area, construction may be subject to building permits. Make sure you have checked with your local authorities to obtain the needed information before the assembly.

Product assembly :

- At least 2/3 people required
- Remove protective film (around 1 hour needed)
- Do not keep children near the assembly area
- Beware of the risk of pinching
- Do not tighten the screws before assembling the whole product
- All assembly steps must be carefully followed
- Check the level of the structure on all sides
- Do not anchor the pergola before assembling the whole product

No changes can be made to the product. Products tampered with by the user are not covered by the warranty, thus being declared as void.

The location should be chosen carefully. It is recommended to avoid mounting your pergola on a rainy day, facing the prevailing winds, and under an overhanging tree.

The pergola must be mounted on a flat-level foundation. It is recommended to install it on a concrete slab or 25x25 cm concrete pads at each post. Please, anchor the pergola properly to the ground using expansion screw.

If you would like to mount your pergola near your house or a building, please check the presence of gutters for water drainage.

Should these instructions not be followed or only partially, the warranty will be voided by the seller.

MAINTENANCE

Regular maintenance is necessary to ensure its longevity and aesthetic appearance.

We recommend to :

- Clean your pergola once or twice a year with fresh water using a sponge or cloth.
- Do not use detergent or an abrasive material.
- Check the tightness of the screws regularly (at least once a year).
- Oil fastening regularly (at least once a year).
- Make sure that nothing hinders the water flow in the gutters (leaves, branches...).
- Remove any water that might stagnate around the legs of the pergola (lift the posts skirts).

MAINTENANCE

This warranty does not cover :

- Normal wear and tear inherent from the products.
- Loss or breakage of any part during unpacking or installation.
- Lack of care, neglect, vandalism, impact with foreign body, force, contact with a brasives material, product aesthetics, disassembly, rebuilding or relocation.
- Force majeure: hail, high winds, storms, snow, floods, lightning etc...
- Product tampered with by the user.

The warranty only takes in account the replacement of spare parts or the provided product, no refund will be issued.

All warranty claims must be made at the sales outlet (store or website) where the product has been purchased.

PARTS LISTS (PER CARTON)



Before proceeding with the assembly of your louvered pergola, it is necessary to check that all parts listed are supplied and not damaged.













Any missing part must be reported within 10 days of delivery.

















You can either go through your local outlet store or make the request directly on our website.



Do not discard the packaging without ensuring that the product is functioning properly.



CARTON 1/5(POSTS AND LOOSE PARTS)

Reference	Parts	Quantity
A0		4
A0-1		2



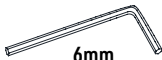

Reference	Parts	Quantity
I0		6
J0		6
K0		2
L0		32
LO-1		34
EO-1		2
MO		66
NO		2
OO		2
PO		2
QO	 6mm	24
RO		24
SO		68

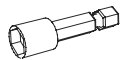
Reference	Parts	Quantity	
S0-1		68	
T0	 10×80	24	
U0	 lock nut	68	
U0-2		66	
W0	 6×12	 4mm	132
W0-1	 5×19	 5mm	6
X0	 6×40	 4mm	66
X0-1	 6×35	 4mm	66
X0-3	 6×16	 4mm	4
V0		66	
Y0	 6×45	 4mm	6

Reference	Parts	Quantity
ZO-1	 4mm	1
ZO-2	 4mm	1
ZO-3	 6mm	1

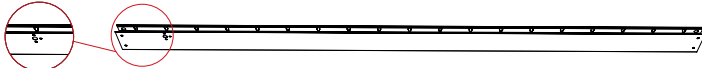
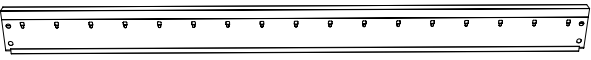
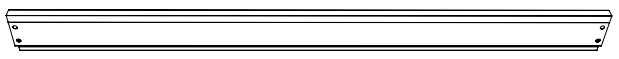
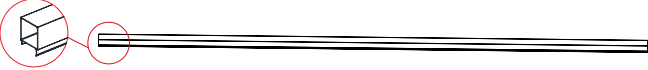

Reference	Parts	Quantity
ZO-4	 6mm	1
ZO-5	 10mm	1
ZO-7		1

CARTON 2/5(BEAMS)

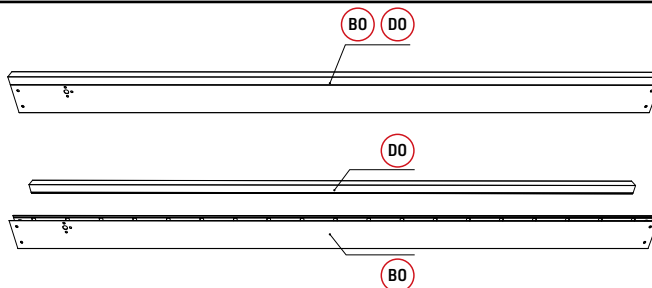

Reference	Parts	Quantity
BO		2
BO-1		2
CO		2
DO		2
EO		1
FO		4
HO		2



CARTON 3/5(LOUVERS)

Reference	Parts	Quantity
GO		10
GO-1		1

CARTON 4/5(LOUVERS)

Reference	Parts	Quantity
GO		10
GO-1		1

CARTON 5/5(LOUVERS)

Reference	Parts	Quantity
GO		12

Steps 1-FRAME

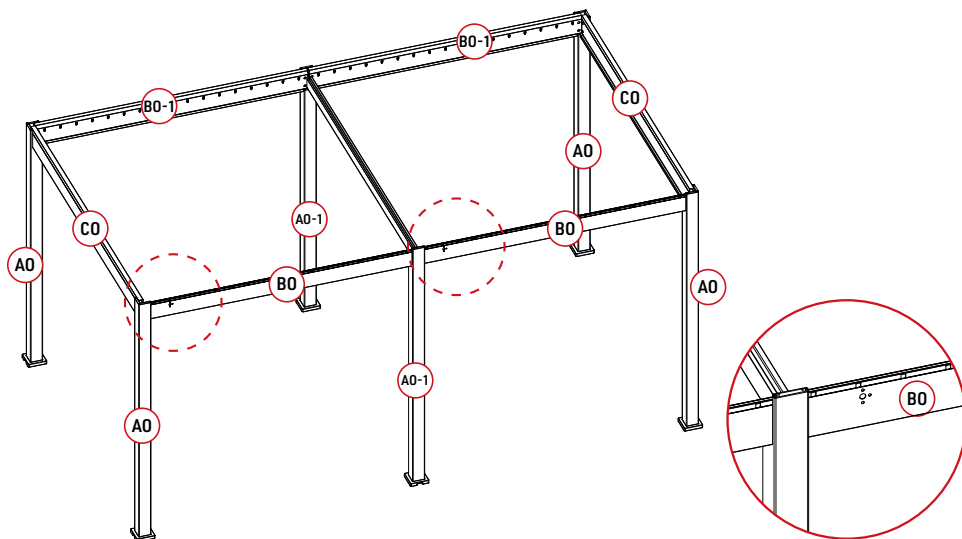

PARTS

Reference	Parts	Quantity
AO		4
AO-1		2





Reference	Parts	Quantity
BO		2
BO-1		2
CO		2
EO		1

Reference	Parts	Quantity
IO		6
JO		6
QO		24
EO-1		2



Reference	Parts	Quantity
XO-1		24
XO-3		4
WO-1		6

Steps 1-1 (FRAME)

Parts

A0		4
I0		4
J0		4
X0-1		16

Tools

Z0-1		1
Z0-2		1

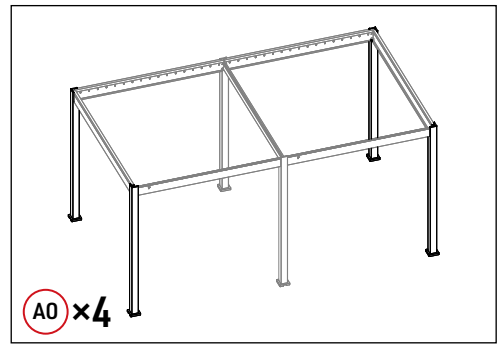

Completion Diagram

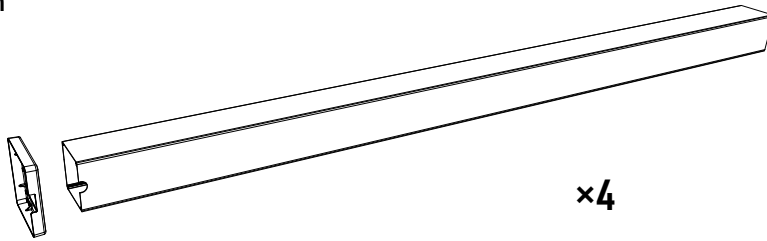

1

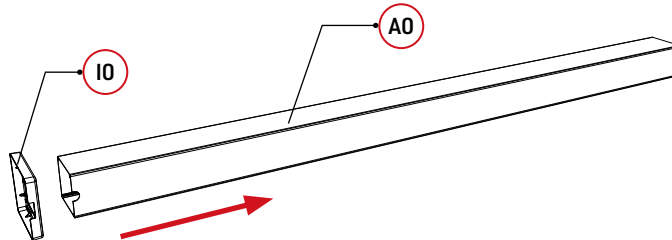

1. Place the **I0** into the **A0**, making sure that the notch around the column **I0** is aligned with the drain outlet at the bottom of the **A0** column, and place it into the column.



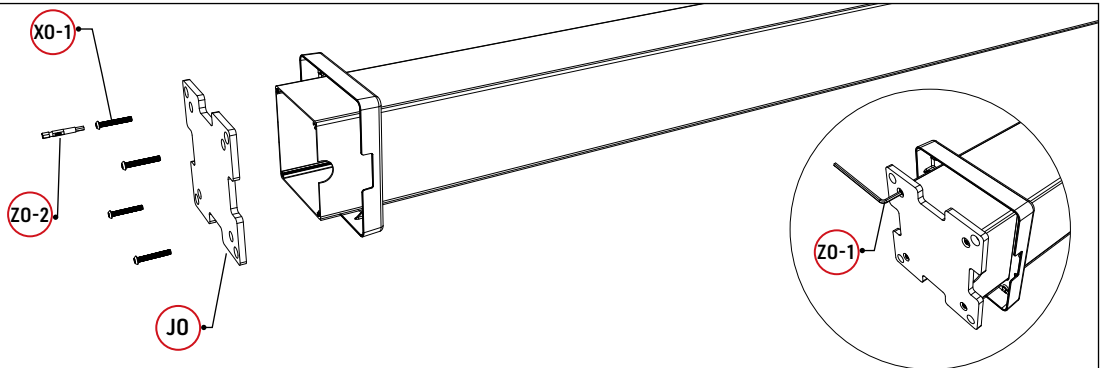

2





2. Use **X0-1** to connect the **J0** base plate to the bottom of the column, and use the hexagonal wrench **Z0-1** to tighten the screws manually.

Steps 1-2(FRAME)

Parts

A0-1		2
I0		2
J0		2
X0-1	 6x35 4mm	8

Tools

Z0-1	 4mm	1
Z0-2	 4mm	1

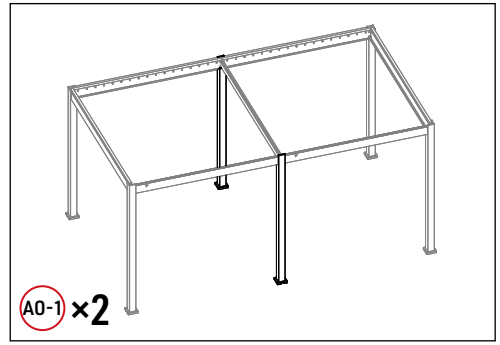

Completion Diagram

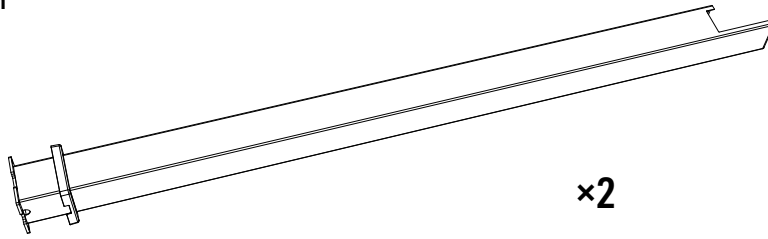

×2

1

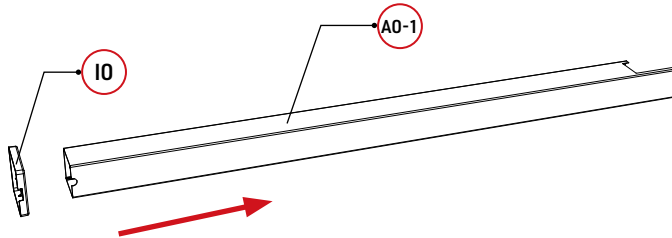

1. Place the **I0** into the **A0-1**, making sure that the notch around the column **I0** is aligned with the drain outlet at the bottom of the **A0-1** column, and place it into the column.

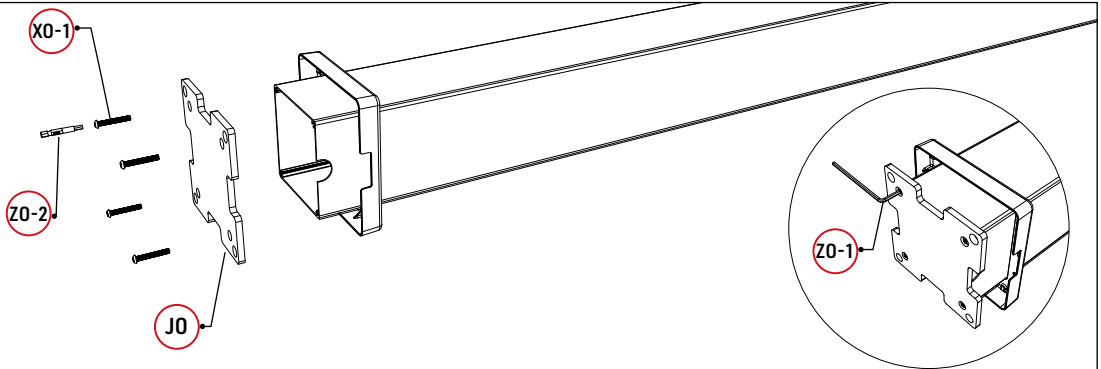

2





2. Use **X0-1** to connect the **J0** base plate to the bottom of the column, and use the hexagonal wrench **Z0-1** to tighten the screws manually.

Steps 1-3(FRAME)

Parts

C0		2
Q0		8

Tools

Z0-3		1
Z0-4		1

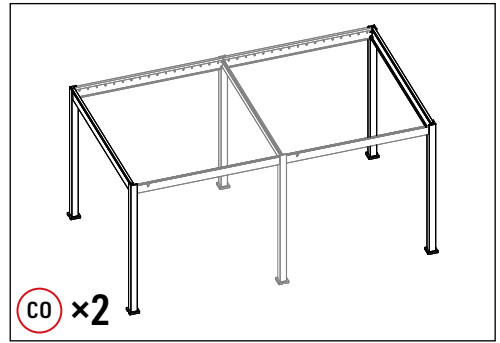

Completion Diagram

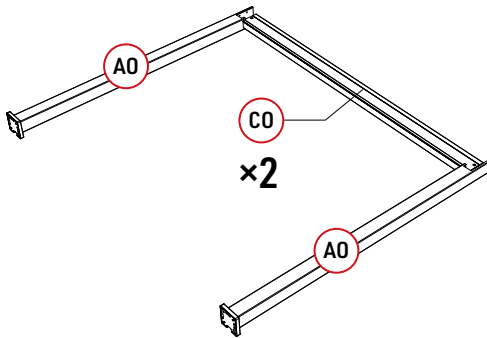

1. Lay the column and beam flat, and put **CO** into the groove of the completed column **AO**.

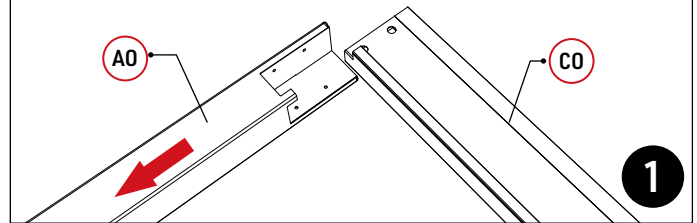

2. Connect **CO** with **AO** using **Q0**.

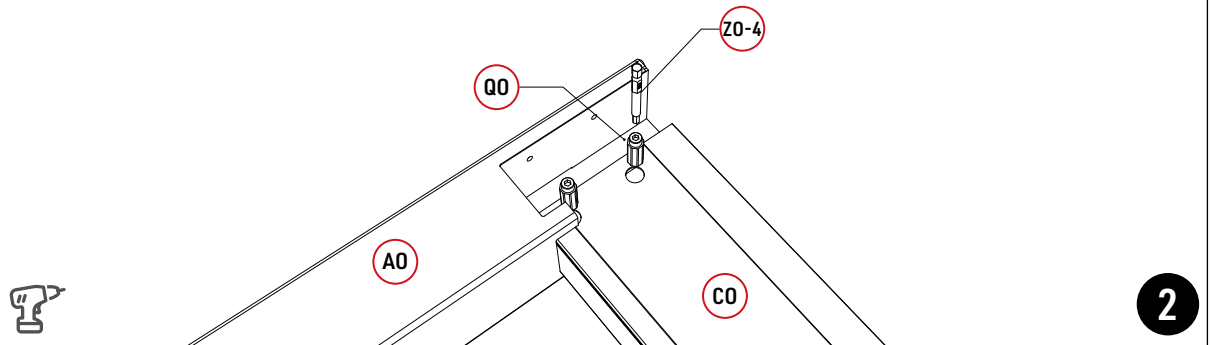

3. Use hex wrench **Z0-3** to tighten manually.

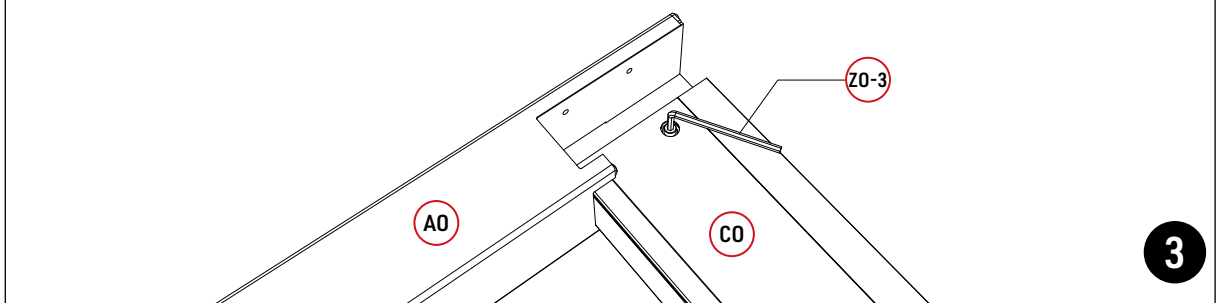

Steps 1-4(FRAME)

Parts

BO		1
BO-1		1

QO		8
----	---	---

Tools

ZO-3		1
ZO-4		1

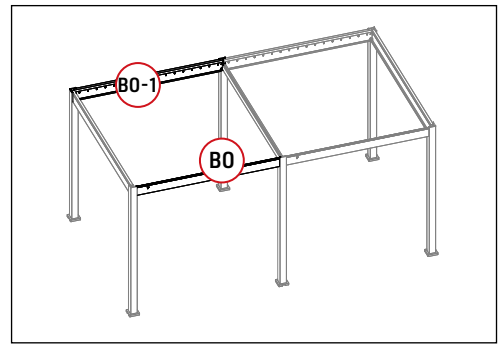

Completion Diagram

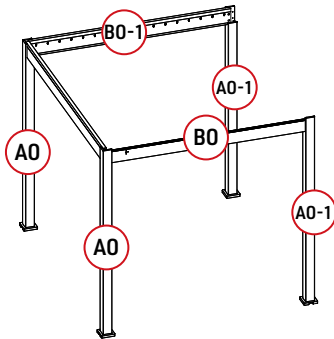

1. Lay the column and beam flat, and put **BO-1** into the groove of the completed column **AO**.

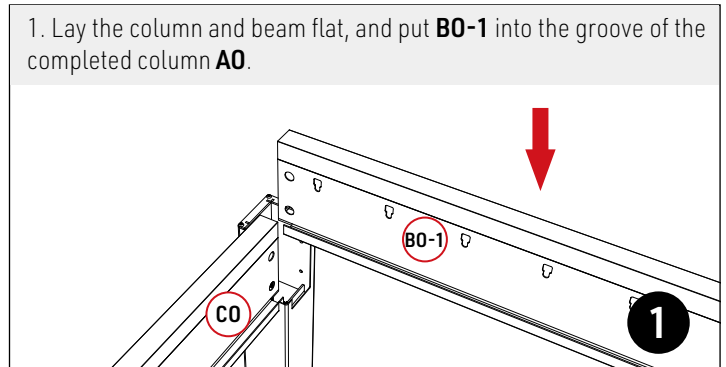

2. Connect **BO-1** with **AO** using **QO**. Use hex wrench **ZO-3** to tighten manually.

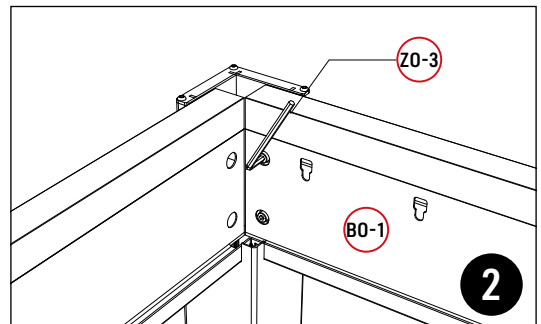
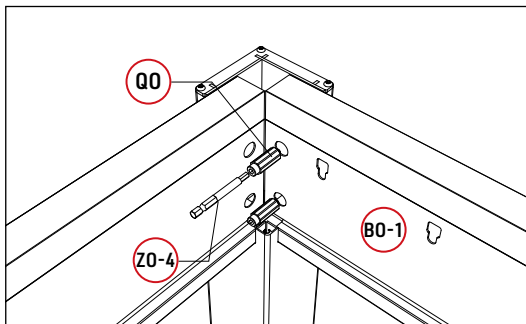

3. Connect **BO-1** with **AO-1** using **QO**. Use hex wrench **ZO-3** to tighten manually. **BO** is installed in the same way

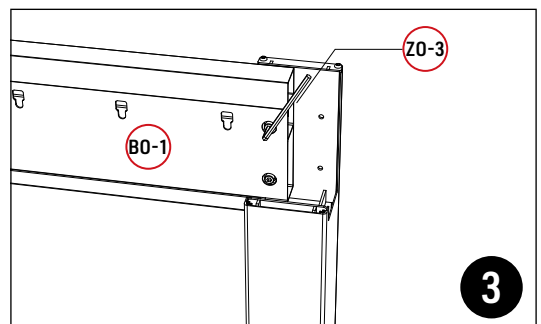
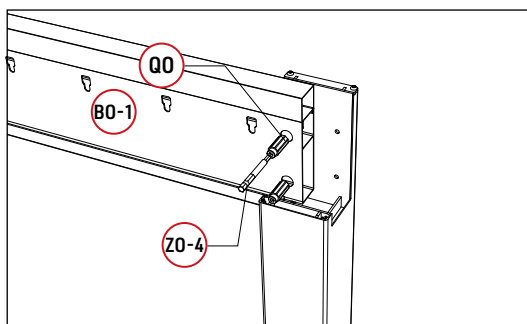

Steps 1-5(FRAME)

Parts

B0		1
B0-1		1

Q0		8
----	---	---

Tools

Z0-3		1
Z0-4		1

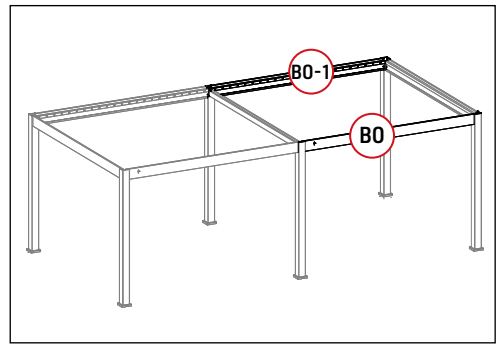

Completion Diagram

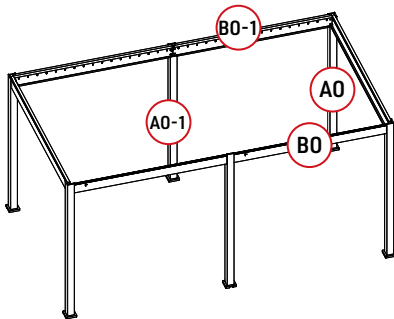

1. Lay the column and beam flat, and put **B0-1** into the groove of the completed column **A0**.

2. Connect **B0-1** with **A0** using **Q0**. Use hex wrench **Z0-3** to tighten manually.

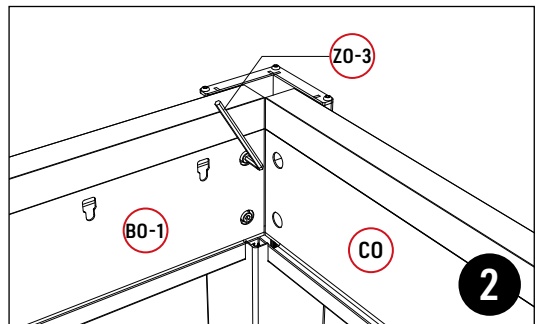
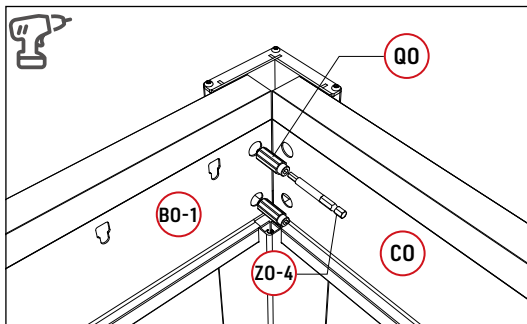



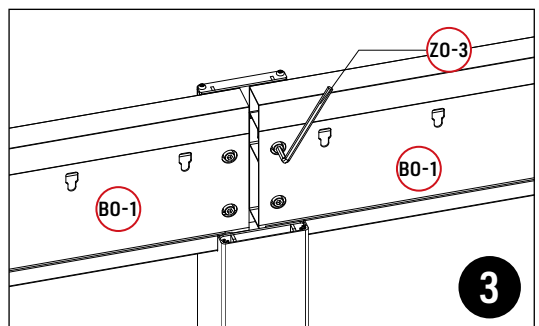
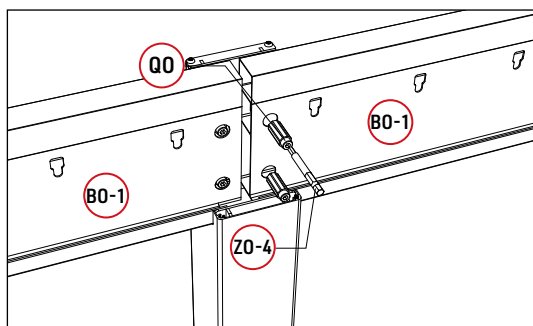

3. Connect **B0-1** with **A0-1** using **Q0**. Use hex wrench **Z0-3** to tighten manually. **B0** is installed in the same way



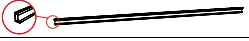

Steps 1-6(FRAME)

Parts

E0		1
EO-1		2
WO-1		6
XO-3		4

Tools

ZO-1		1
ZO-2		1
ZO-7		1

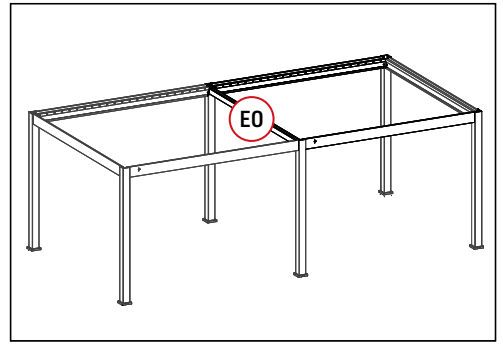

Completion Diagram

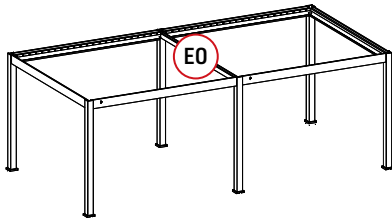

Use **EO-1** to fix both sides of **EO**.

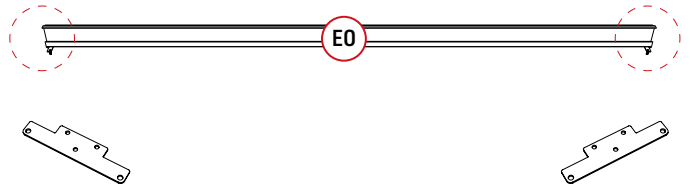

1. Use **WO-1** and **ZO-7** on both sides to fix **EO-1** on **EO**

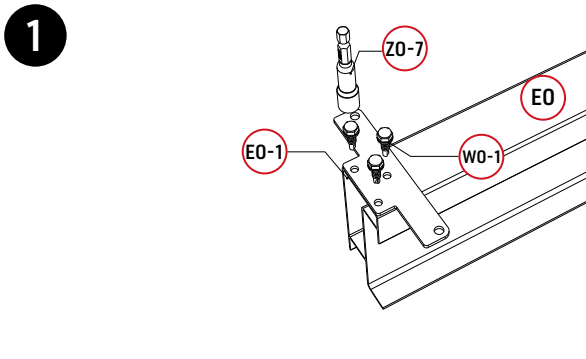

2. Place the installed **EO**

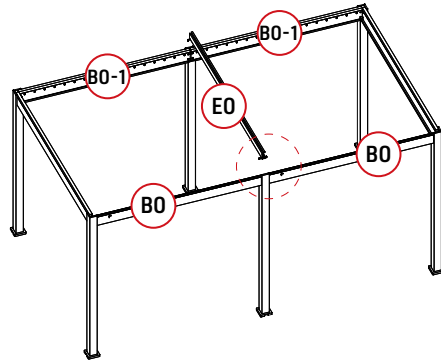

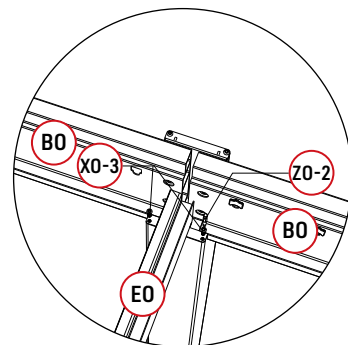
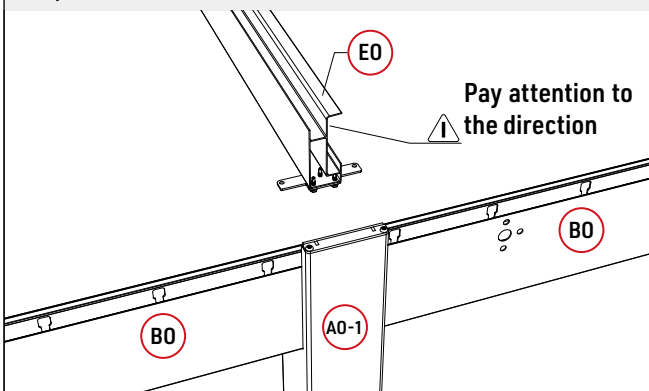

3. Pay attention to the direction of **EO**. Use tool **ZO-2** to secure the **XO-3** to the center column.



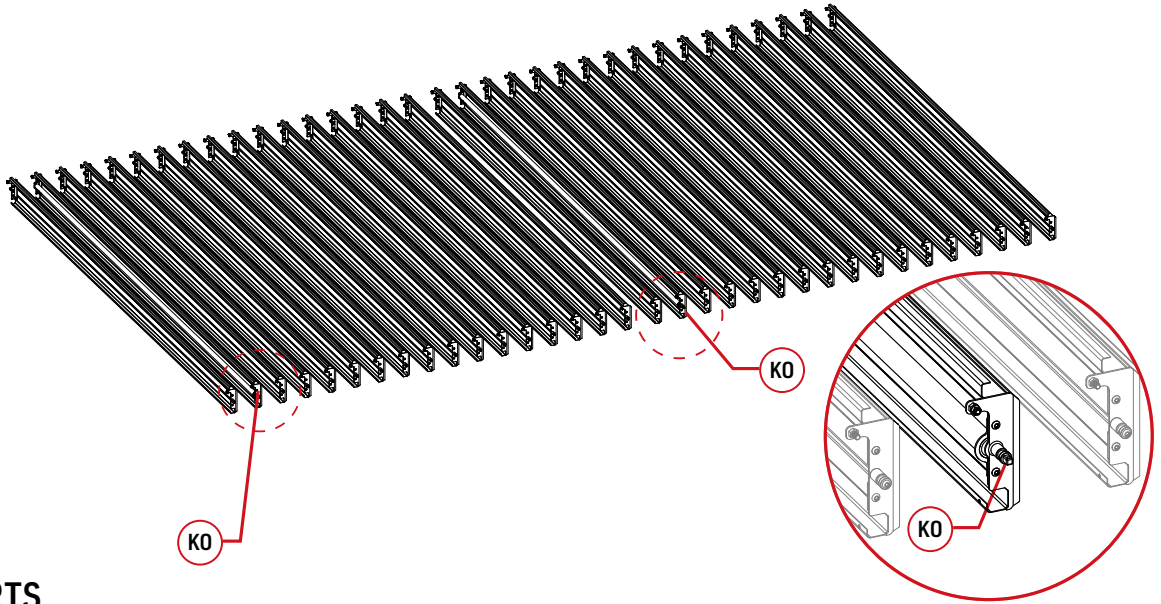







Steps 2-LOUVERS



PARTS

Reference	Parts	Quantity
GO		32
GO-1		2

Reference	Parts	Quantity
KO		2
LO		32
LO-1		34
MO		66
WO	 6×12 4mm	128
UO	 lock nut	66

Reference	Parts	Quantity
SO-1		68
XO	 6×40 4mm	66

Steps 2-1 (LOUVERS)

Parts

LO		32	UO	lock nut	66
LO-1		34	XO	6-40 4mm	66
MO		66			

Tools

ZO-1	4mm	1
ZO-2	4mm	1
ZO-5	10mm	1

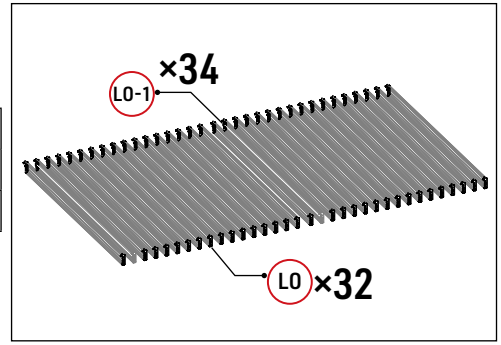

Completion Diagram

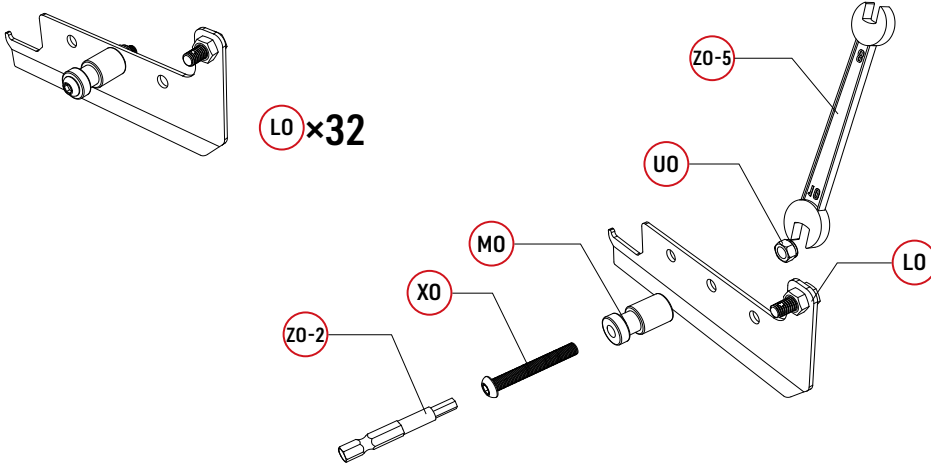

Use **ZO-5** to fix the **UO** and complete the assembly of the **LO**.



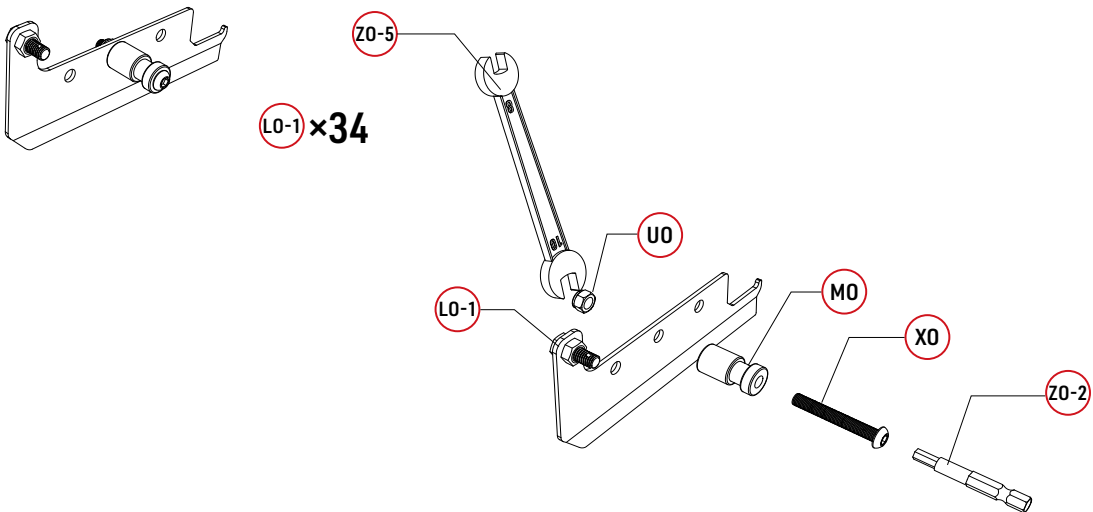



Completion Diagram





Use **ZO-5** to fix the **UO** and complete the assembly of the **LO-1**.

Steps 2-2(LOUVERS)

Parts

GO-1			2				
KO		2	WO			4mm	8
LO-1		2	UO		lock nut	8	

Tools

ZO-1		4mm	1
ZO-2		4mm	1
ZO-5		10mm	1

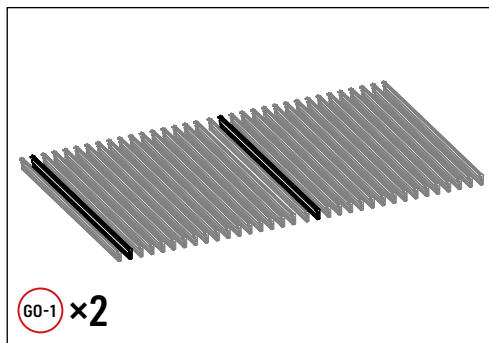

Completion Diagram

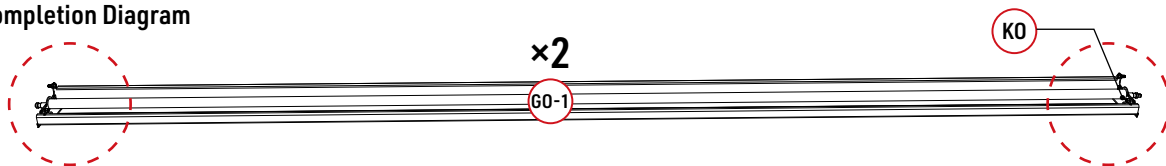

Remove the screws at both ends of **GO-1**.

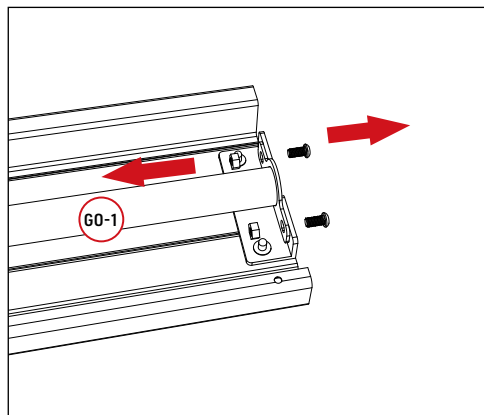
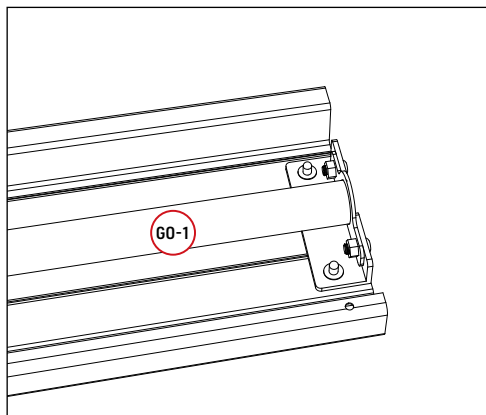



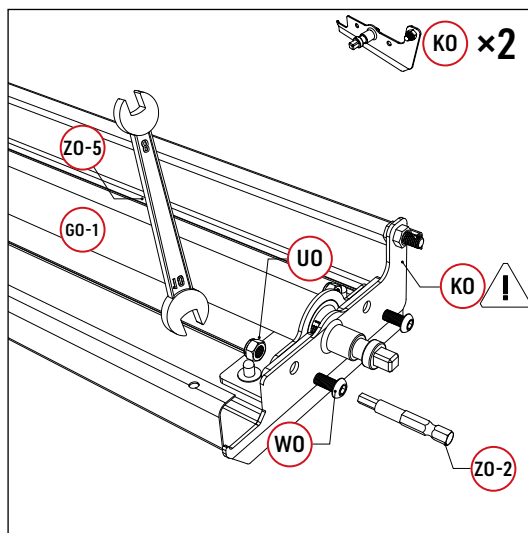
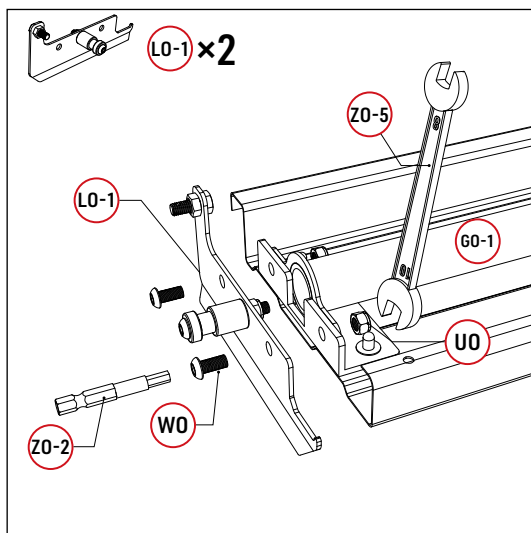



Install the connecting pieces at both ends of the louver.





Steps 2-3(LOUVERS)

Parts

GO		34				
LO		32	WO			128
LO-1		32	UO			128

Tools

ZO-1		1
ZO-2		1
ZO-5		1

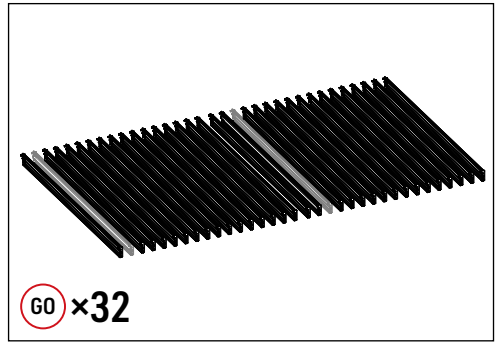

Completion Diagram

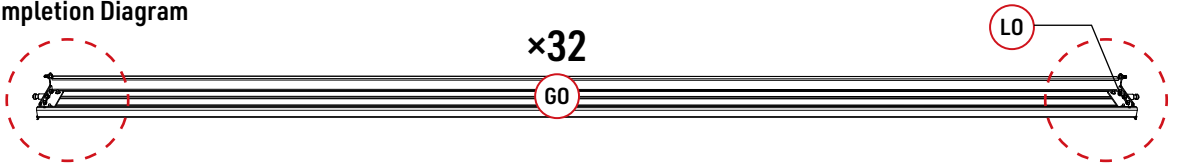

Install the connecting pieces at both ends of the louver.

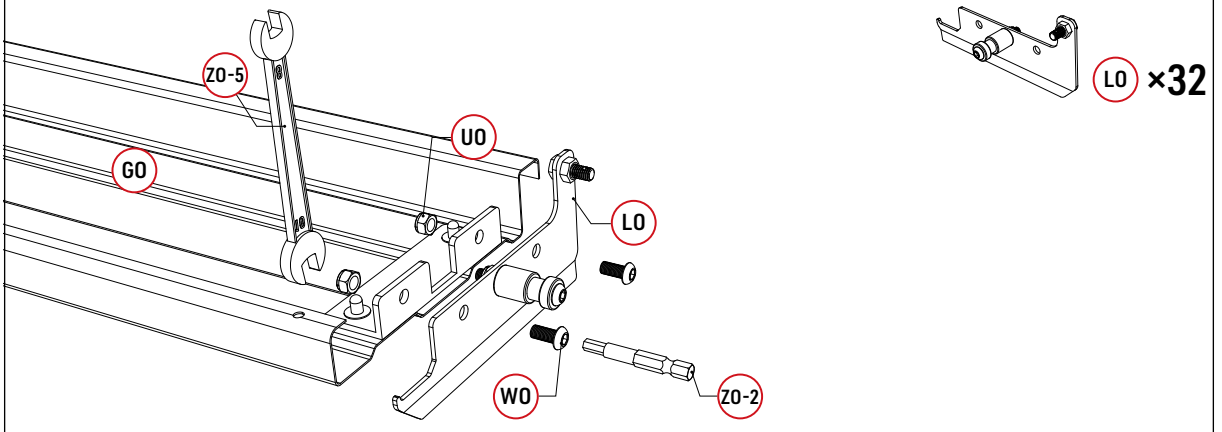

Install the connecting pieces at both ends of the louver.

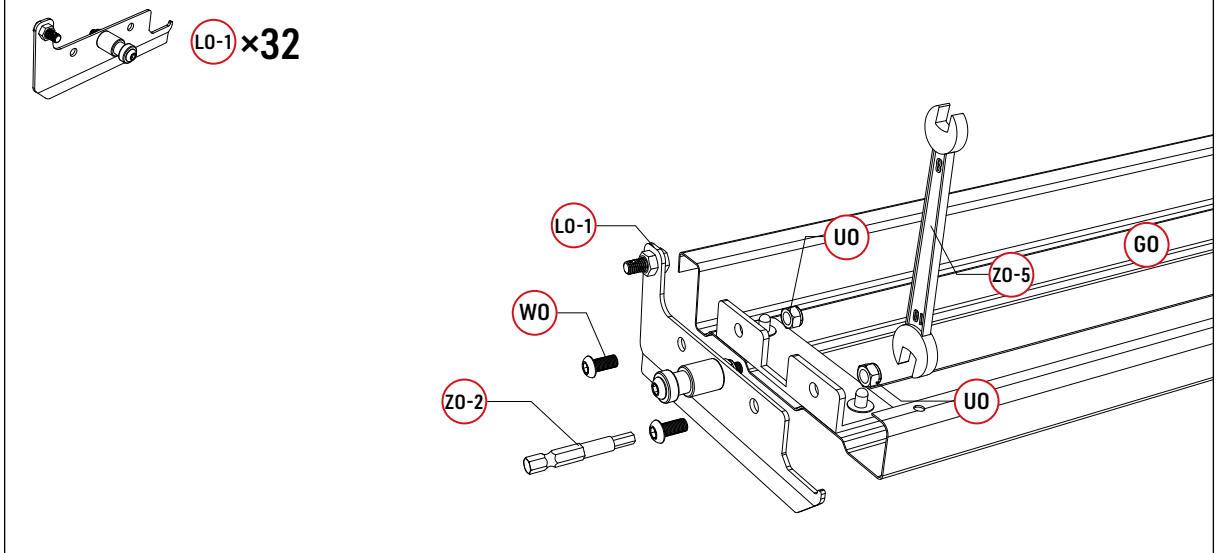

Steps 2-4(LOUVERS)

Parts

S0-1		68
------	---	----

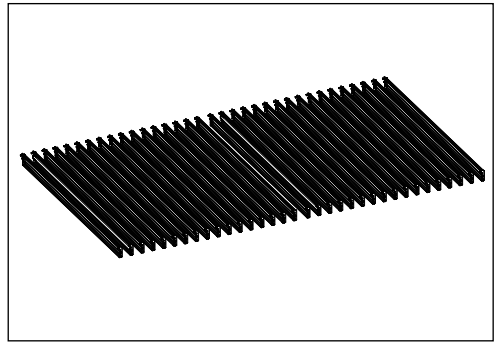

Install **S0-1** on both ends of the louver

G0-1 ×2

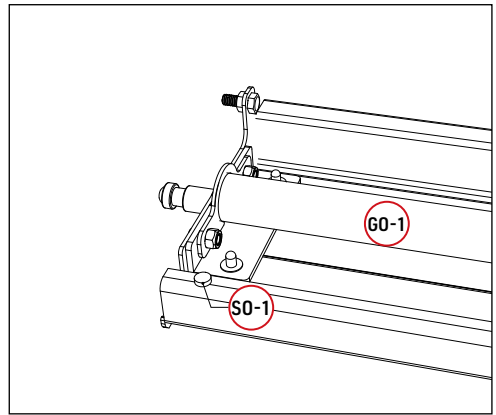
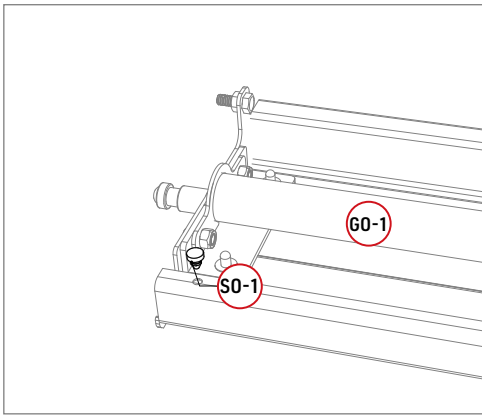

Install **S0-1** on both ends of the louver

G0 ×32

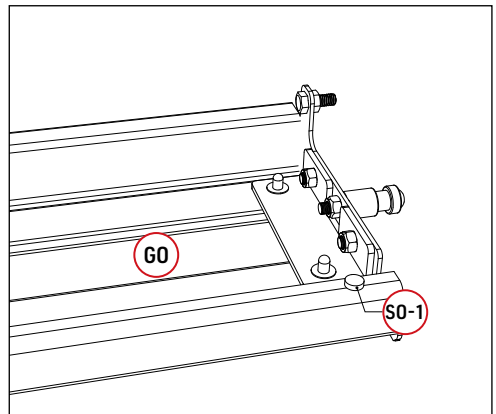
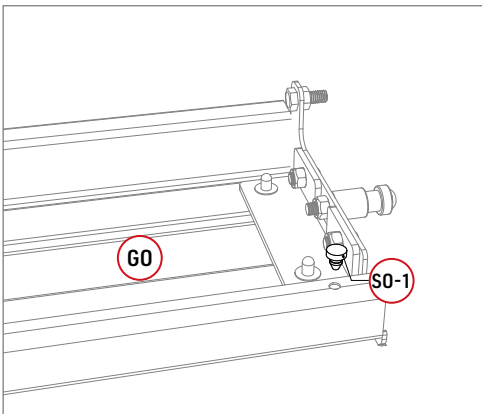

Steps 3-CONNECTORS

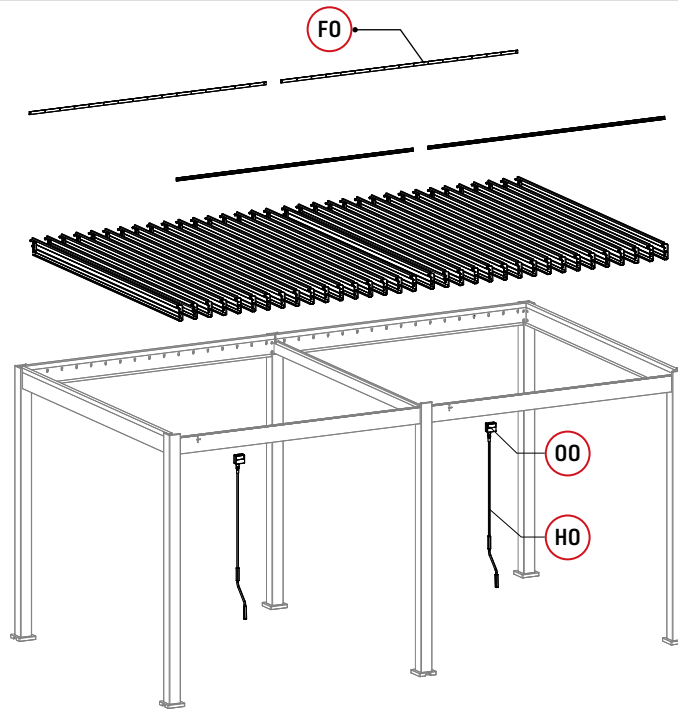

PARTS

Reference	Parts	Quantity
FO		4
HO		2

Reference	Parts	Quantity
NO		2
OO		2
PO		2
RO		24
SO		68

Reference	Parts	Quantity
UO	 lock nut	4
UO-2		64
VO		64
YO	 6×45 4mm	6
TO	 10×80	24

Steps 3-1 (CONNECTORS)

Parts

S0		68
----	---	----

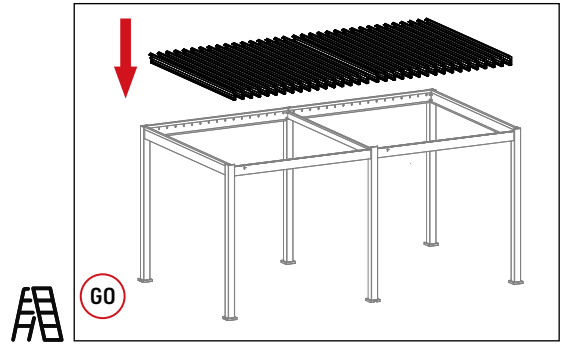

Place **GO-1** into the beam

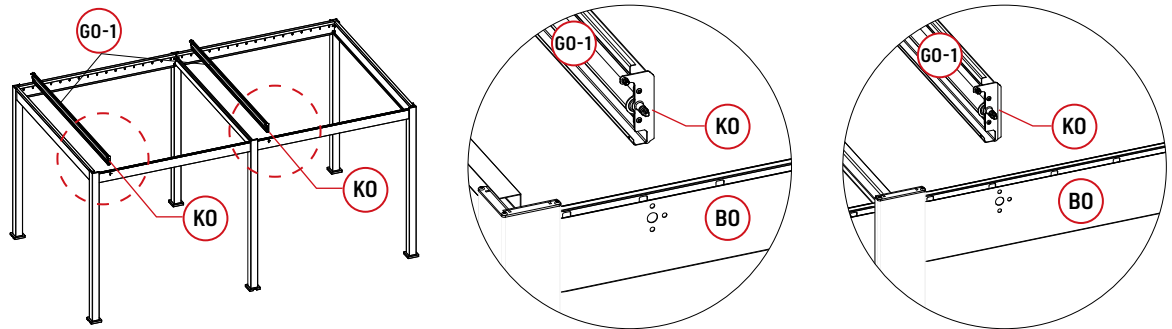

Place the **KO** end into the cavity of the **BO** as shown in the picture.

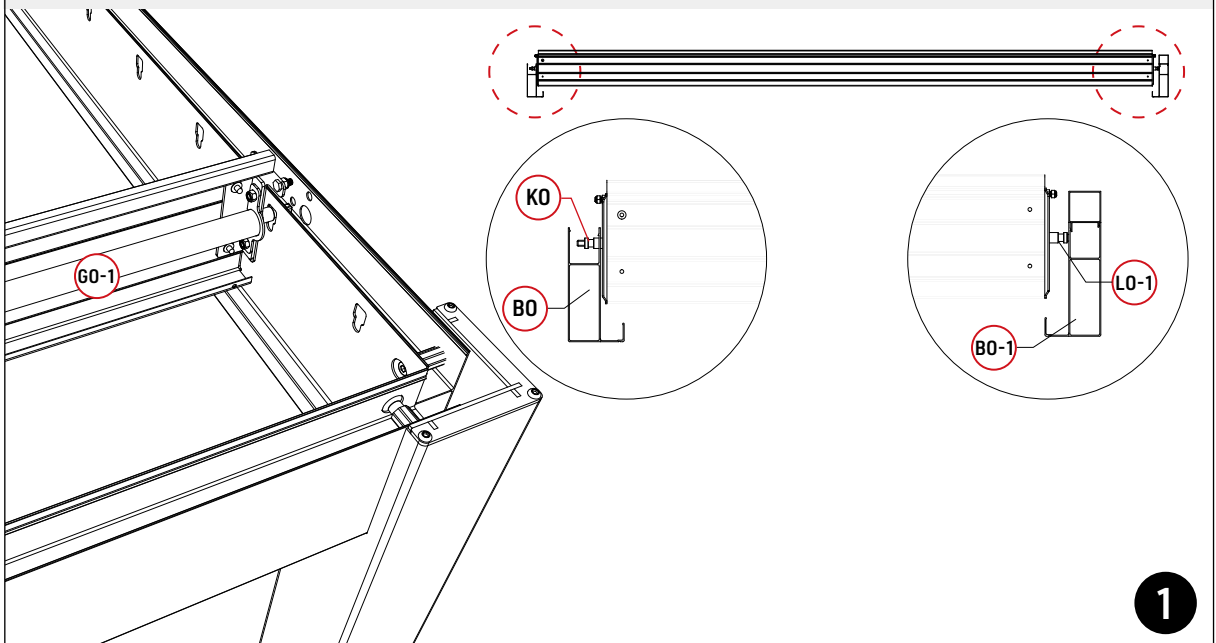

1

Then put another section into **B0-1** and lock the groove.

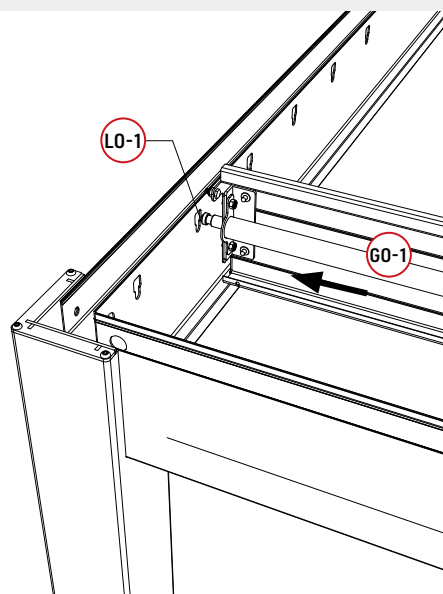
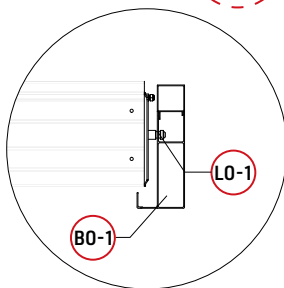
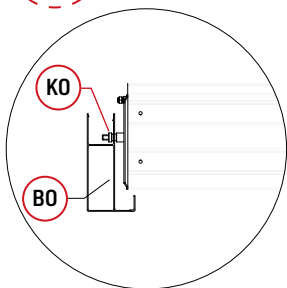

2

Put other louvers into it.

GO ×32

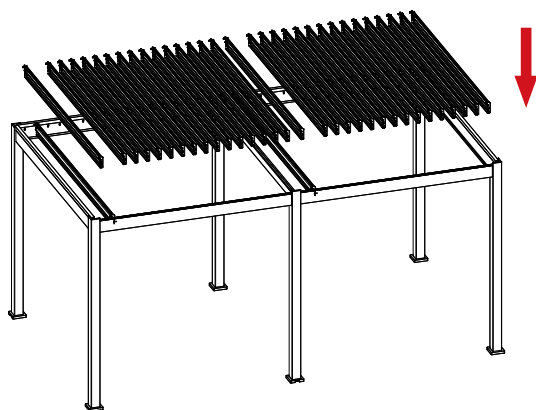

S0 covers on both sides of the shaft.

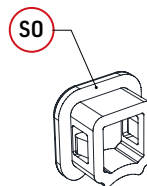
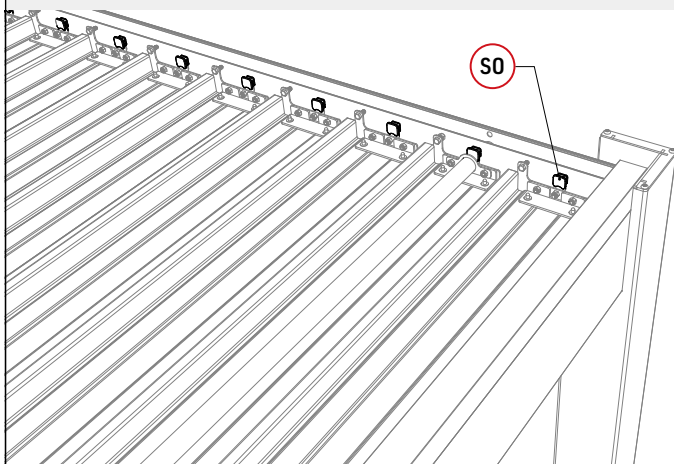

Steps 3-2(CONNECTORS)

Parts

HO		2	YO		6
NO		2			
OO		2			
PO		2			

Tools

Z0-1		1
Z0-2		1

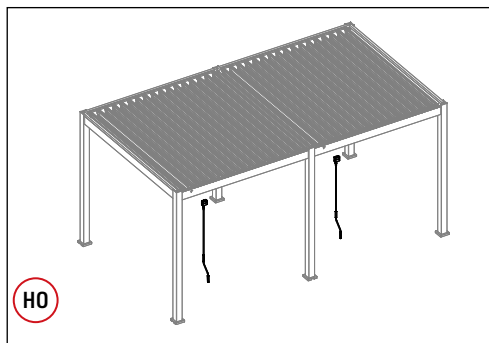

HO

1. Insert the **PO** spindle into the hole.

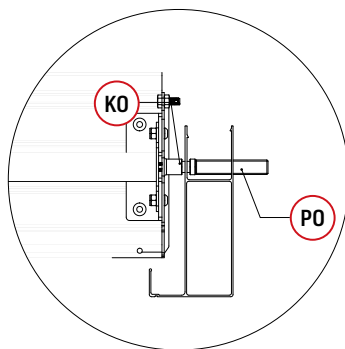
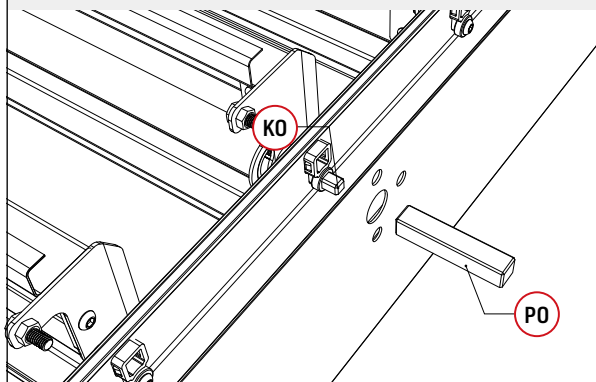

2. Place **OO** first, then assemble **NO**, after that, fix it with **YO**.

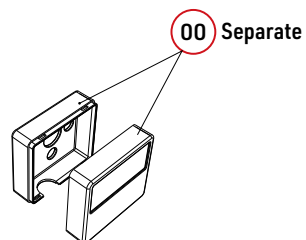
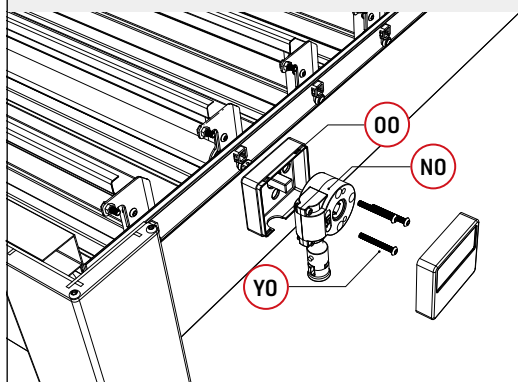



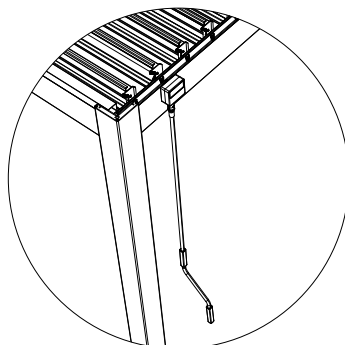
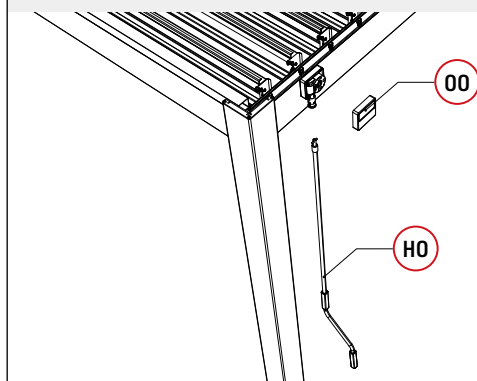

3. Fasten **NO**, assemble **HO**.





Steps 3-3(CONNECTORS)

Parts

F0		4
U0	 lock nut	4
V0		64
U0-2		64

Tools

Z0-1	 4mm	1
Z0-2	 4mm	1
Z0-5	 10mm	1

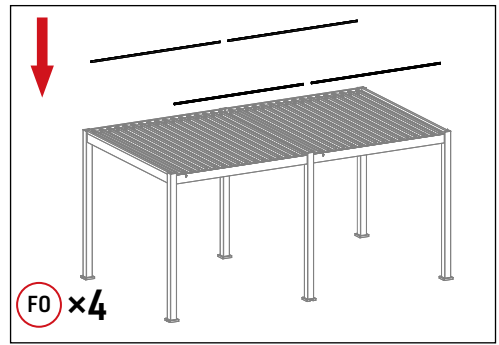

Place the **K0** end into the cavity of the **B0** as shown in the picture.

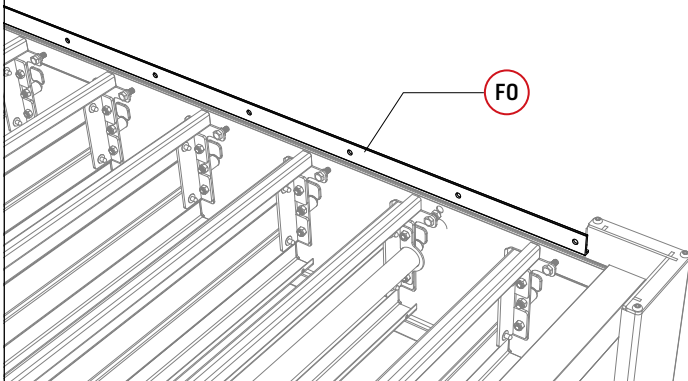

Use **U0** at both ends of spindle **G0-1** to fix both ends of **F0**.

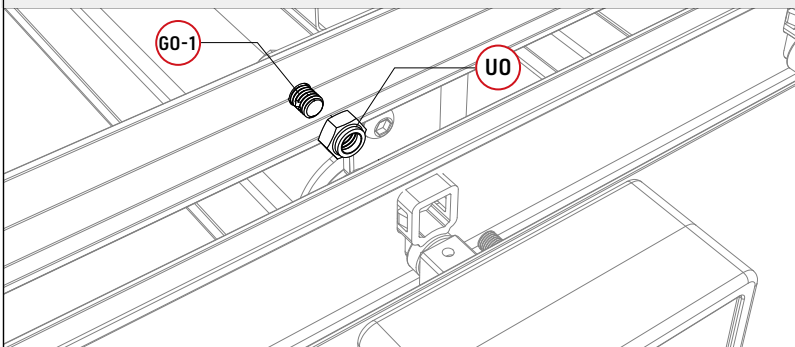

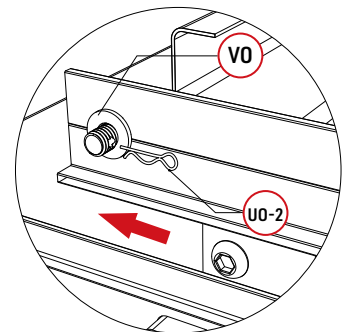
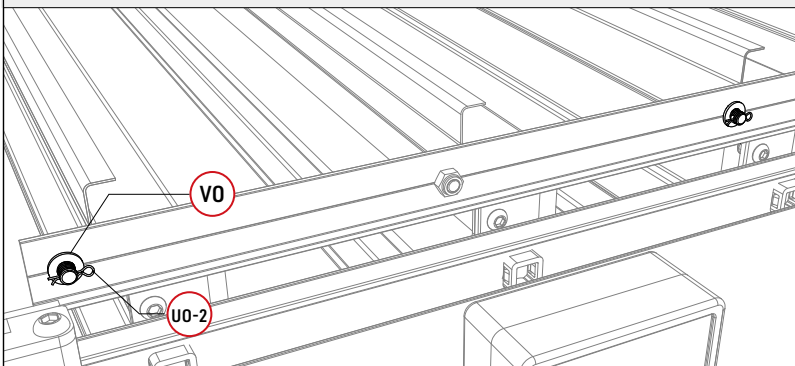

Please the gasket **V0** shown as below. Insert the **U0-2** into the hole of end cap.



Steps 3-4(CONNECTORS)

Parts

DO		2
RO		24
TO		24

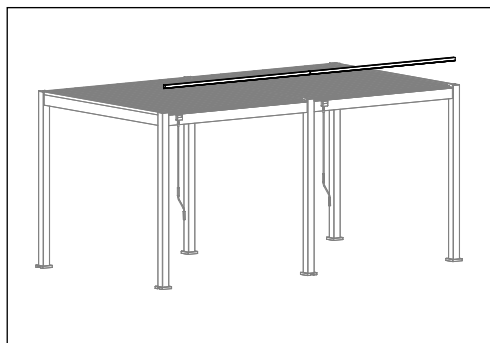

Cover the holes on the beam by using **RO**.

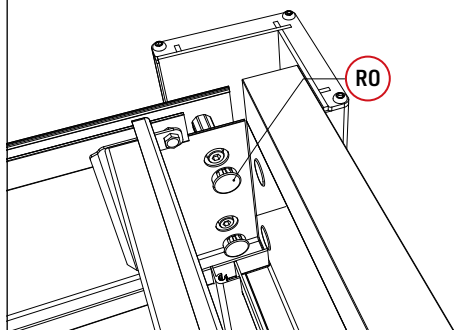

Cover **DO** on the beam.

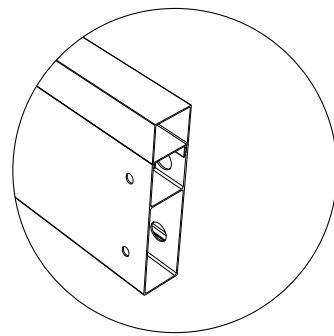
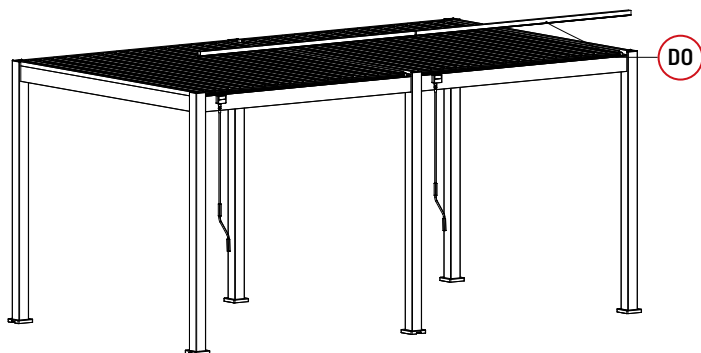

Check size. Use a $\varnothing 12\text{mm}$ drill bit to drill holes on the position where to fix the steel plate, then fix steel plate with **TO**. Use a M17 wrench to fasten the **TO**.

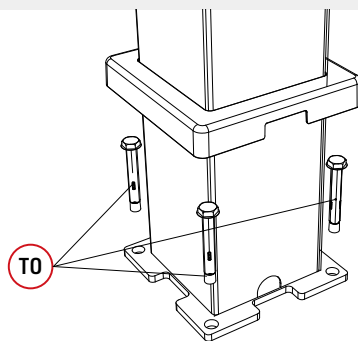
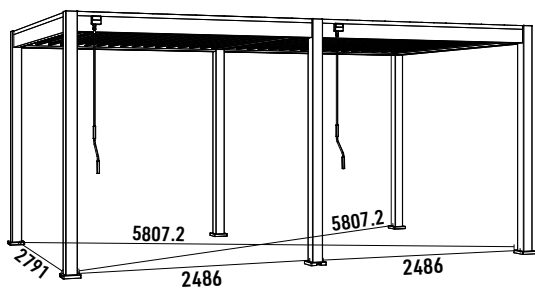

12MM



M17